

thinklogical[™]

PDU 4/4

Product Manual



Thinklogical Inc.
100 Washington Street
Milford, Connecticut 06460 U.S.A.

Telephone (203) 647-8700
Fax (203) 783-9949



Copyright Notice

Copyright © 2009. All rights reserved. Printed in the U.S.A.

Thinklogical™, a subsidiary of Logical Solutions, Incorporated
100 Washington Street
Milford, Connecticut 06460 U.S.A.
Telephone (203) 647-8700

All trademarks and service marks are property of their respective owners.

Subject: PDU 4/4, Power Distribution Unit Product Manual
Revision: Rev A, June 2009



Table of Contents

PREFACE..... **IV**
About this Product Manual.....**iv**
Conventions Used in this Manual**iv**

INTRODUCTION **5**
The Logical Solution..... **5**
System Features **5**
Technical Specifications **6**

PART 1: HARDWARE..... **7**
Contents **7**
Mounting the PDU 4/4 **7**
 Rack Mount or Desktop **7**
 Front Panel Display and Buttons **8**
 Convection Cooled **8**
Front Panel View **8**
Rear Panel View **9**
 Power Connections **9**
 Status LEDs **10**
 USB Firmware Upgrade Port **10**
 Serial Interface **10**
Installation..... **11**
 Set Up **11**
 Cascading PDU Boxes **12**
 Order of Installation Events **12**

PART 2: SOFTWARE..... **13**
Program Storage..... **13**
Communicating with the PDU 4/4 **13**
 Programming the System **13**
 Programming Access **13**
 Log In **14**
Commands **14**
 Command Principles **14**
 HELP command **15**
 Exit / Quit..... **15**

| | |
|--|-------------------------------------|
| PART 3: SAFETY REQUIREMENTS | 21 |
| Symbols found on the product | 21 |
| Regulatory Compliance | 21 |
| North America | 21 |
| Australia & New Zealand | 21 |
| European Union | 21 |
| Standards with Which Our Products Comply | 22 |
| Supplementary Information..... | 22 |
| Product Serial Number | 23 |
| Connection to the Product | 23 |
| | |
| PART 4: THINKLOGICAL™ SUPPORT..... | 24 |
| Customer Support | 24 |
| Website | 24 |
| Email | 24 |
| Telephone | 25 |
| Fax | 25 |
| Product Support..... | 25 |
| Warranty..... | 25 |
| Return Authorization..... | Error! Bookmark not defined. |
| Our Address | 26 |
| | |
| APPENDIX A: ORDERING INFORMATION..... | 27 |
| | |
| APPENDIX B: QUICKSTART GUIDE | 28 |

Preface

About this Product Manual

This product manual is divided into four sections, for Hardware, Software, Safety Requirements and Product Support. These are sub-divided to help you easily find the topics and procedures you are looking for. This manual also contains Appendices and a Glossary.

Part 1 – Hardware: This section of the manual contains all the information and instructions on how to assemble your equipment.

Part 2 – Software: This section of the manual contains all the procedures on how to configure your equipment.

Part 3 – Safety Requirements: Thinklogical™ strongly recommends that you read this section of the manual prior to starting the hardware assembly.

Part 4 – Product Support: Thinklogical™ provides the best customer support available. If you have any questions or need to contact the company, please refer to this section of the manual.

Conventions Used in this Manual

As you read this manual you will notice certain conventions that bring your attention to important information. These are **Notes** and **Warnings**. Examples are shown below.



Note: Important Notes appear in blue text preceded by a yellow exclamation point symbol, like this.

A note is meant to call the reader's attention to helpful information at a point in the text that is relevant to the subject being discussed.



Warning! All Warnings appear in red text, followed by blue text, and preceded by a red stop sign, like this.

A warning is meant to call the reader's attention to critical information at a point in the text that is relevant to the subject being discussed.

Before starting any procedure, it is recommended that you read the instructions thoroughly before proceeding.

Introduction

The Logical Solution

Thinklogical's Power Distribution Unit (PDU 4/4) is an AC Power Switch that provides the ability to remotely control the power to eight devices. It gives system administrators the capability to restart a "locked up" network device from anywhere on their network. The PDU 4/4 provides eight individually-controlled AC power outlets that are switched off and back on as desired. The PDU 4/4 communicates with its control terminal using a serial interface.

The easy to use, PDU 4/4 provides the means to control all devices with simple commands to turn Power Off / On to reboot any one port, multiple ports, port groups or all devices. Power restarts can be sequenced using programmed time delays to minimize surge or allow drive spin-up time. Rear panel LEDs are also provided to show the status of each port.

Your configuration can be easily expanded by adding PDU 4/4 boxes and a serial cable for each. A single serial interface integrates the control of all PDU 4/4s in your application. Up to sixteen PDU 4/4s can be cascaded together to control multiple systems from one common user interface.

Each PDU 4/4 utilizes two banks of four outlets, each outlet individually switches 10 Amperes maximum with each bank rated at 15 Amperes total. The PDU 4/4 is designed for rack mounting (1U) or desktop.

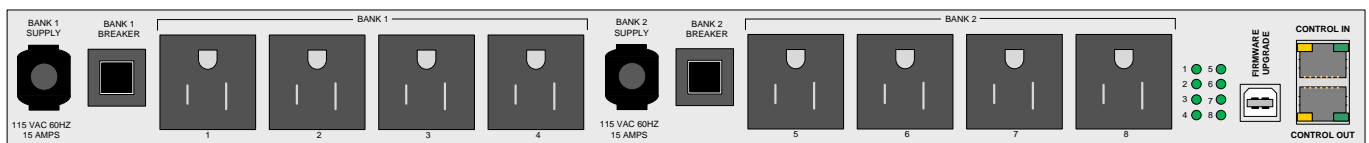

Figure 1: Rear View of PDU 4/4 (PDU-000001)

System Features

Each PDU4/4 system includes the following features:

- Eight individually-controlled AC power outlets
- Dual 15 Amp (max) circuits, four 10A (max) outlets per circuit
- Redundant DC power supplies for built-in I/O and control circuits
- Individually programmable Reboot Time Delay on each outlet
- Solid state zero-crossing relays to minimize power spikes
- Easily expandable configuration
- Password Security
- User-definable Port Names and Port Groups
- Front panel display for easy system set up and configuration
- Current monitoring of each port to determine if connected unit turns on
- Software updates available on ftp.thinklogical.com

Technical Specifications

| | |
|---|---|
| Storage Temperature | -20 to 70°C (-4 to 158°F), 10 to 90% RH, non-condensing |
| Power Supply Voltage | 100 to 240 VAC, 50/60 Hz |
| Power Consumption | 10 Watts, typical |
| Heat Dissipation | 34 BTUs per hour |
| Panel Connectors | (2) Power Cords (2) Power Switch/Circuit Breakers (8) AC Power Outlets (8) Port Status LEDs (1) USB (B) - Firmware Upgrade Port (2) Dual RJ45 – Control In/Out Serial Ports Refer to Section 3.1.1 for more details on the Rear Panel |
| Front Panel Display | 2 x 24 Liquid Crystal Display |
| Operating Temperature and Humidity | 0 to 50 °C (32 to 122 °F); 5 to 95% RH, non-condensing |
| Enclosure Dimensions | Approx. 12.25in x 17.50in x 1.75in high (31.1cm x 44.5cm x 4.4cm high) |
| Weight | 11 lb (4.99 kg) |
| Shipping Weight | 27 lbs (12.25 kg) |
| Cables and Adapters | CAT5 (RJ45) Cable Assembly, 6 Feet (CBL000001-002MR) DB9F To RJ45F Adapter (ADP-000008-R) |

Part 1: Hardware

Contents

When you receive your Thinklogical™ PDU 4/4, you should receive the following items:

- PDU 4/4 Unit
- CAT5 (RJ45) Cable Assembly, 6 Feet (CBL000001-002MR) – Qty 1
- DB9F To RJ45F Adapter (ADP-000008-R) – Qty 1
- Product Manual CD

All physical connections to the product use industry-standard connectors.

Mounting the PDU 4/4

You may choose to rack mount your PDU 4/4 or place it on a shelf or desktop (rubber feet included). The front panel display should be visible and front panel buttons need only to be accessible if initial setup of the system is required. All connections are made to the rear of the chassis.

Rack Mount or Desktop

The PDU 4/4 may be installed in an EIA-standard 19 inch rack (1U tall), or placed on a shelf or desktop. For shelf/desktop use, rubber feet are provided and the rack mounted brackets may be removed. The PDU 4/4 chassis does not need to be opened or accessed. The sturdy metal case allows units to be stacked, as required.



Note: Be sure to leave adequate ventilation space on both sides of the units, especially if units are being stacked. Each rack mount bracket is held on by 4 screws. The brackets may be positioned so that the unit sits forward or recesses in your rack. If the brackets are removed or repositioned, it is not necessary to re-use the extra rack mount screws.

Front Panel Display and Buttons

The front-panel LCD display should be visible and accessible for system setup. The front panel buttons are used to configure the unit and to review existing PDU 4/4 configurations. More detailed information on the Front Panel can be found in the section, **Front Panel View**.

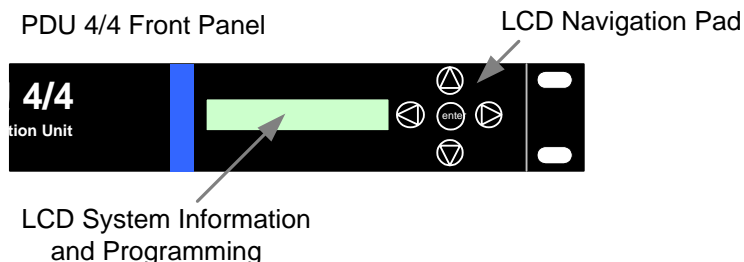

Figure 2: PDU 4/4 Front Panel LCD Display

Convection Cooled

The PDU 4/4 does not require special cooling or ventilation other than what is normally provided in the equipment rack. No fan means that it does not add to the ambient noise in your equipment room and it is less prone to equipment failure. Be sure not to block the air vents on the sides of the unit, and leave space on both sides. If mounted in an enclosed rack, it is recommended that the rack have a ventilation fan to provide adequate airflow through the unit(s).

Front Panel View

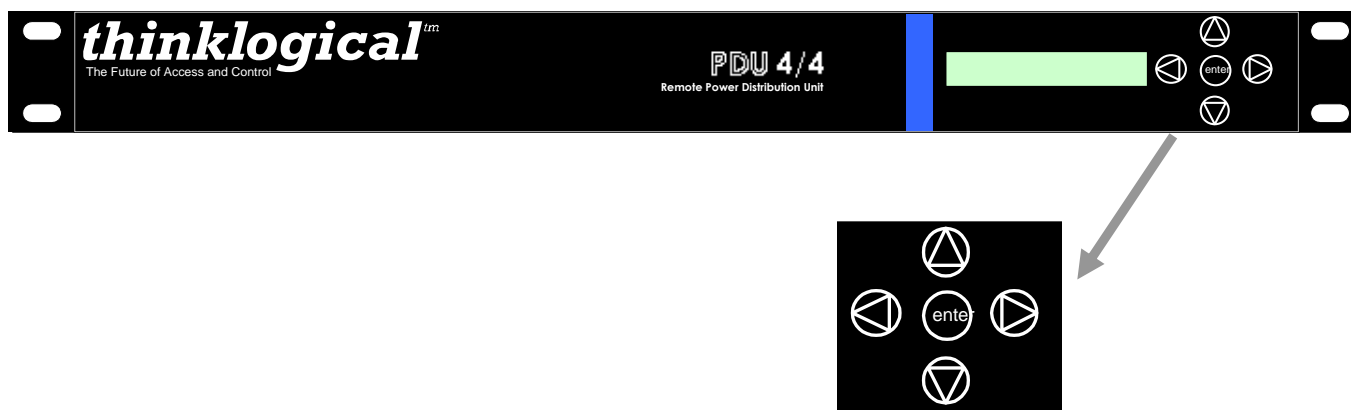

Figure 3: PDU 4/4 Front Panel

Use the Up and Down arrow keys to scroll through the Main Menu (Port Power, System). Once the main menu choice is shown on the display, press the Enter key. Then, use the Left and Right arrow keys to navigate through the menu options.

The menu is arranged as follows:

| Display | Modifiable | Description |
|--------------------|------------|------------------------------------|
| *Port Power | | |
| Port 1 | Yes | Displays status of power on Port 1 |
| Port 2 | Yes | Displays status of power on Port 2 |
| Port 3 | Yes | Displays status of power on Port 3 |
| Port 4 | Yes | Displays status of power on Port 4 |
| Port 5 | Yes | Displays status of power on Port 5 |
| Port 6 | Yes | Displays status of power on Port 6 |
| Port 7 | Yes | Displays status of power on Port 7 |
| Port 8 | Yes | Displays status of power on Port 8 |

| Display | Modifiable | Description |
|-----------------------|------------|---|
| *System | | |
| DAISY Position | No | Location in DAISY Chain |
| Ctrl Rev | No | Revision of PDU |
| Offset Current (Tare) | Yes | Calibrate current monitor on all ports. |
| Debug Values | Yes | Factory Debug Facility |

Offset Current Tare is only available from the front panel. This menu option sets a zero current reference and stores it in non-volatile memory. To use this feature all ports must be off. Once ports are off, set the Offset Current Tare to Yes, it will revert back to No when the calibration is complete.

Rear Panel View

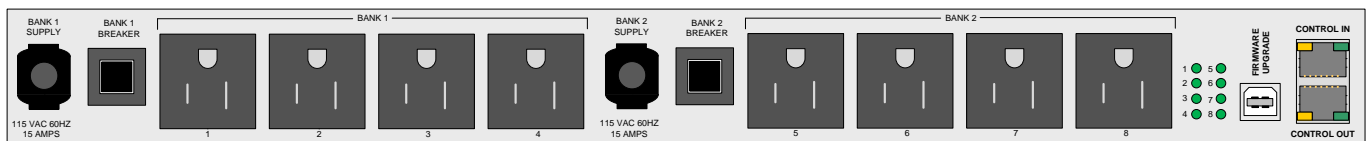

The rear panel consists of (2) Power Cords, (2) Circuit Breakers, (8) AC Power Outlets, (8) Port Status LEDs, (1) USB Firmware Upgrade Port, and (2) Console Ports.

Power Connections

The rear panel consists of two Banks: Bank 1 and Bank 2. Each Bank consists of (1) AC Input Power Cord, (1) Power Switch/Circuit Breaker, and (4) AC Power Outlets.

**Bank 1 provides AC power for Ports 1 through 4 and AC/DC Power Supply 1;
Bank 2 provides AC power for Ports 5 through 8 and AC/DC Power Supply 2.**

Domestic

Each AC Input Power Cord is outfitted with a NEMA 5-15P plug for all US/Domestic orders. Each Bank also has a 15 Amp Power Switch/Circuit Breaker that supplies the AC power to the bank of four switched outlets and one internal power supply. If either Power Switch/Circuit Breaker is turned on, one of the internal redundant power supplies will power the PDU and the applicable bank will be available to provide power. If both banks are off, the PDU will not function and all outputs will be off.

The four Switched AC Outlets per Bank consist of NEMA 5-15R nominal-115VAC power outlets. Bank 1 consists of Ports/Outlets 1 through 4 and Bank 2 consists of Ports/Outlets 5 through 8. Each outlet is independently controlled and can switch up to 10 Amperes; however, **the total power draw for each Bank of Ports/Outlets must not exceed 15 Amperes.**

The two internal power supplies that are used to power the PDU system are redundant. This feature will allow the unit to maintain power in an unlikely event of a DC Power Supply failure. Upon recovery from a power failure to the PDU, the unit will switch the Ports to the same state they were in prior to the PDU losing power.

Status LEDs

The LEDs on the rear panel correspond to each of the (8) Switched AC Outlets. (For example, LED 1 shows the status of Outlet/Port 1, LED 2 shows the status of Outlet/Port2, etc.) When the status light of a Outlet/Port is lit green, the Outlet/Port has power.

USB Firmware Upgrade Port

A USB-B connector is provided on the rear panel of the PDU for easy firmware upgrades. Firmware updates are possible via a USB cable and an application that runs on a Windows (2000, XP, or Vista) PC.

Please visit <http://ftp.thinklogical.com/ftp/visualization/updates/> for any updates and instructions.

Serial Interface

The PDU has (2) RJ45 serial connectors on the rear panel: **CONTROL IN** and **CONTROL OUT**.

If using a single PDU, connection to the **CONTROL IN** port is required. The **CONTROL IN** port is used to connect to a Logical Solutions Secure Console Server or a serial terminal.

If cascading multiple PDU units, the first PDU will be connected to the controlling terminal using the **CONTROL IN** port. The **CONTROL OUT** port will be connected to the **CONTROL IN** port of the next unit using a straight-through RJ45 cable, and so on.

Installation

All physical connections to the product use industry-standard connectors. Non-supplied cables that may be needed are commercially available. All connections are found on the rear of the unit.

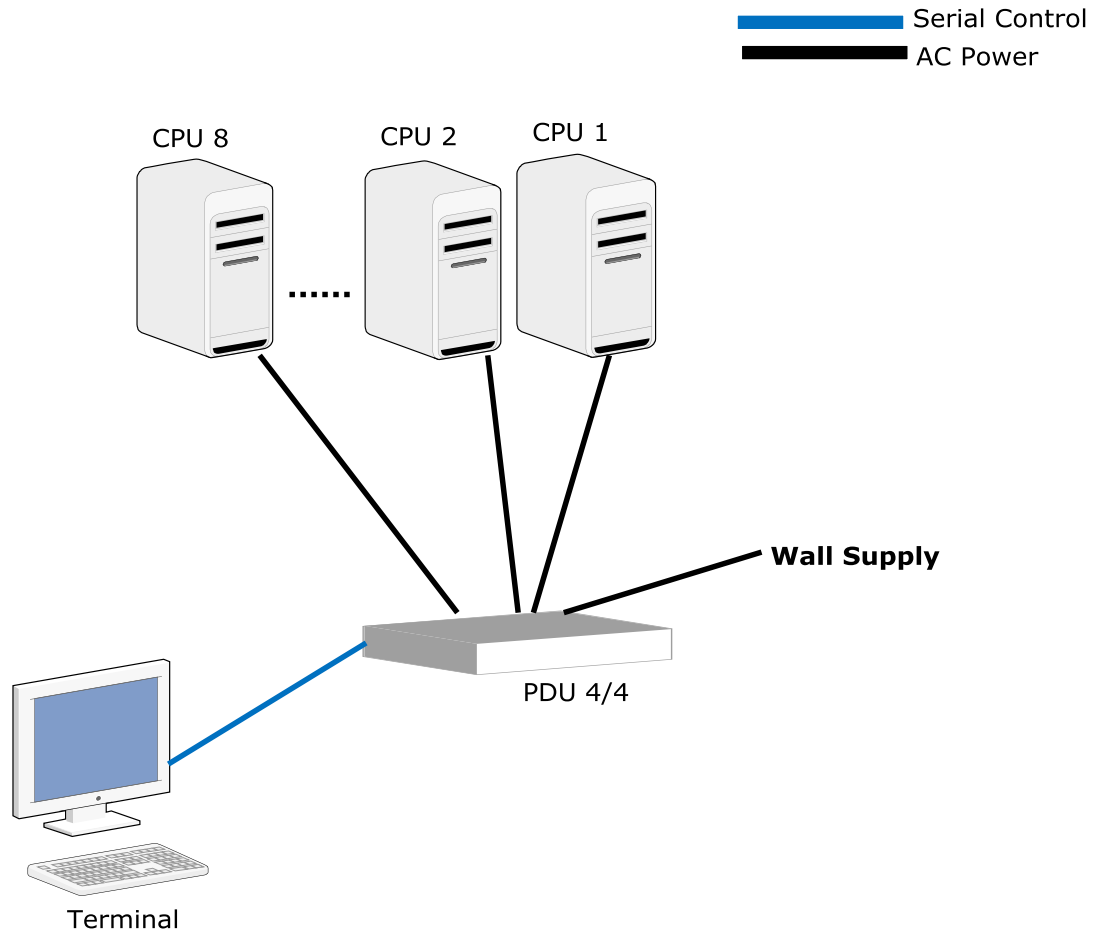

Figure 5: PDU 4/4 Typical Application

Set Up

The PDU is designed to connect to a Logical Solutions Secure Console Server or to standalone. Each device port of the Secure Console Server is a compatible RS-232 serial port designed to connect to the PDU's **CONTROL IN** port. The PDU is installed by first connecting to the device port using commands in the Console Server, then using PDU commands once connected. Refer to the Console Server manual for Console Server information.

1. Use an Ethernet cable to connect the desired device port to the PDU's **CONTROL IN** port. The connection is made with the device port configured as follows:

Port Setting for your Terminal Device

If your switch does not have a dedicated 'Power Manager' port, you can configure a serial port to the following settings:

- Configure an RS-232 serial port as a **DTE** port.
- Configure the port for **9600** baud, **8** data bits, **No** Parity, **1** Stop Bit.
- Use Adapter ADP-000008-R to connect a serial port to the Control In

Cascading PDU Boxes

If more than eight switched AC Power ports are required, the PDU 4/4 configuration can be expanded by daisy-chaining up to sixteen (16) PDU 4/4 systems. The first PDU 4/4 assumes the “Master” role, with the Master PDU 4/4's CONTROL OUT Port connected to the next box's CONTROL IN Port. An RJ45 straight-through serial cable (Thinklogical PN: CBL000001-002MR) must be used.

Box IDs

Units are only assigned master or slave status after logging in, until log in, all boxes display a box id of 0. The first box assumes the Master box ID of 1. Additional PDU 4/4 boxes are designated a “Slave” status and are automatically designated with the next sequential box ID (numbered 2 through 16). All commands issued to the master unit referencing a slave unit will be passed on to the designated box. The program parameters for each PDU 4/4 are stored in that unit; the Master unit only passes commands to the slave units.



Note: If an intermediate unit in such a chain of PDU 4/4's loses power, the control and operation of the PDU 4/4 configuration stops at the unit without power.

Order of Installation Events

Please refer to the **Quickstart Guide** included in the contents of the shipment for detailed instructions. A copy of the Quickstart is also available in **Appendix B (pg. 29)**.

Part 2: Software

Program Storage

All programmed data in the PDU 4/4 is stored in non-volatile memory in the event of a power failure. The PDU 4/4 will return each port to its previous state (on or off) when power returns to the unit.



Note: Many PC-based communications packages offer the ability to buffer the serial data that has been entered and displayed, so that it may be copied and saved to a file. In this case, you can keep a copy of the programmed data for your reference, if required.

Communicating with the PDU 4/4

Programming the System

The PDU 4/4 uses a simple serial user interface. It accepts commands from a serial terminal or terminal emulation package. The command language also provides status information upon request.

In order to enter any command function, the user must gain access to the PDU 4/4 COMMAND MODE by entering a password to log on. Each command is completed by pressing the 'Enter' or 'Carriage Return' (<CR>).



Note: In this manual, pressing 'Enter', 'Return' or <CR> represent the same action.

Programming Access

Once connected to the PDU 4/4's **CONTROL IN** serial port, the following access and programming commands may be used. Invalid commands or unauthorized access attempts will not affect the PDU 4/4. The programming interface will automatically log out after 5 minutes of idle time.

1. Connect your programming terminal to the **CONTROL IN** port.
2. Press 'Enter' or <CR> on the keyboard to establish communication. Your display should show "**Password:**".

If you do not get the **Password** prompt (or any other activity), check your connections and your terminal's configuration.

thinklogical™

Log In

The PDU 4/4 is password protected at Log In. The factory-set password is **pass** (case-sensitive) which may be changed by the System Administrator.

As you enter the password, the display will show '*' for each character entered:

- The PDU 4/4 is shipped with a default Case Sensitive Password of **pass**.
- Entering an invalid password causes the unit to request the password again.
- Password entry is case sensitive.

When Logged In, the command prompt will show "**PDU 4/4>**".

Commands

Command Principles

Serial Access

Commands are executed from the Serial terminal. You must log in order to access any programming commands.

Abbreviation

Commands may be abbreviated by typing only enough characters to differentiate 1 command from another.

Ports and Groups

Commands can be entered for individual Ports, either by name or by number; for a range of port numbers separated by a dash (e.g., **5-8**), any combination of port numbers, separated by a comma (e.g., **1,4,5,8**); or for a **Port Group**. A Port Group is defined when more than one Port is assigned an identical name (e.g., **SUN**) and the port name is used in a PDU 4/4 command.



Note: In this manual, pressing 'Enter', 'Return' or <CR> represent the same action.

Global Commands

For multiple-PDU 4/4 configurations, many commands will accept a **box ID of zero (0)** to generate a **Global Command** that will execute the desired operation in **all** connected boxes.

Global commands include **0** (the digit zero) to operate all connected PDU 4/4 box ID's, and **ALL** or **all** for all port IDs within a box or a number of cascaded boxes.

Command Replay

Commands may be "replayed" by pressing the up arrow.

HELP command

A HELP command provides a summary of the commands and syntax for the PDU 4/4. Type "help" and press Enter or <CR> to access the HELP file at any time after you've logged in.

```
PDU 4/4> help
exit                close session
quit               close session
buttons            <b> <e | d>    front panel button enable/disable
help              display this help or help for a command
history           display command history
name              <b> <name> <p#> name outlets
off               <b> <p>      turn an outlet or group of outlets off
on               <b> <p>      turn an outlet or group of outlets on
passwd           change password
reboot           <b> <p>      reboot an outlet or group of outlets
rbdelay         <b> <p> <dly> port reboot off time before reset
status          <b>          display outlet status
version         <b>          display software version(s)

<b> = (box # | all)  <d> = disable  <dly> = delay  <e> = enable
<n> = name         <t> = time     <p> = (port # | name | all)
```

Command Help

To check the syntax of a command, type help space and the command name.

help - Help Menu

Typing "help" from the command line will access the **HELP** menu, which reviews the programming parameters for the PDU 4/4 system.

Typing help 'command name' will give specific information for each command.

Exit / Quit

The Exit Command Logs the user off and returns the 'Session Ended'. You will be immediately logged off of the system. You must then log back in to perform functions.



Note: Logging In starts a Timer that will automatically log the current user off if no activity is detected over a 5 minutes period. In this case, the user will see "Session timed out"

The System will automatically timeout and log off after 5 minutes of idle time (no terminal activity).



Note: The following commands are presented in alphabetical order. Do not type the angle brackets, <>, when entering data.

Buttons - Front Panel Button Enable/Disable

The Front Panel Buttons can be disabled to prevent unauthorized control of the outputs of the PDU 4/4. The LED indicators will continue to operate, showing a solid green LED indicator for an 'on' indication and no indicator for 'off'. If buttons are enabled, selecting on/off from the front panel will turn that outlet On or Off immediately.

```
PDU 4/4> help buttons
Syntax: buttons <b> <e | d>
Description: Enable or disable front panel button control.
```

```
<b> = (box # | all)  <d> = disable  <dly> = delay  <e> = enable
<n> = name  <t> = time  <p> = (port # | name | all)
```

Examples:

- Enable Front Panel Button control on Box 1 **buttons 1 enable**
- Disable Front Panel Button control on all PDU 4/4s **buttons 0 disable**

history – Display Command History

The history command will show the past 16 commands. This data is not stored in non-volatile memory.

```
PDU 4/4> help history
Syntax: history
Description: Display previous command history.
```

```
<b> = (box # | all)  <d> = disable  <dly> = delay  <e> = enable
<n> = name  <t> = time  <p> = (port # | name | all)
```

name - Define Port Names

The name command allows the user to assign names to each of the ports to assist in the administration of the ports. Ports with identical names are grouped together since commands can be issued to control the boxes by name or by port number.

The Port Names can be changed to any string of **1 to 16 characters** (including all printable characters) not including 'space' or 'comma'. Port names cannot start with a number.

```
PDU 4/4> help name
Syntax: name <b> <p> <n>
Description: Max. of 16 alphanumeric characters. Must not start with a number.
```

```
<b> = (box # | all)  <d> = disable  <dly> = delay  <e> = enable
<n> = name  <t> = time  <p> = (port # | name | all)
Ports and Boxes may be referred to by all, name (implying a group) or number.
Ranges of ports may be specified as 1-4 = 1,2,3,4. All may also be used.
```

The Define Port Names command allows the user to give each port an *Alias* that is a more meaningful name and allowing the grouping of outlets. The Port Number is not changed or affected by renaming the Port, and may always be used to control the port.

Examples:

- **name 1 Sun 1,3,5** assigns the alias of **Sun** to Box 1, Ports 1, 3, and 5
- **name 0 Sun 1-4** assigns the alias of **Sun** to all Boxes, ports 1 through 4
- **name 0 Sun ALL** assigns the alias of **Sun** to all Boxes, all ports

***Default names are 'DEVICE1' through 'DEVICE8' for Ports 1-8, respectively.

***Port Names must be at least one character, and can be up to 16 characters long, and can include any printable characters except for 'space' or 'comma', and cannot start with a number.

Port Groups

Port Groups can be formed and operated by assigning identical names to two or more ports. All ports with identical names within one PDU 4/4 are grouped together, if the user enters an operational command for that name. All ports with identical names in ALL daisy-chained PDU 4/4 boxes will be operated on, if the user enters a valid GLOBAL (box ID = 0) command.

off – Turn a Port Off

The off command is used to turn off a port or group of ports.

```
PDU 4/4> help off
```

```
Syntax: off <b> <p>
```

```
Description: Turn an outlet or group of outlets off.
```

```
<b> = (box # | all)   <d> = disable   <dly> = delay   <e> = enable
```

```
<n> = name   <t> = time   <p> = (port # | name | all)
```

```
Ports and Boxes may be referred to by all, name (implying a group) or number.
```

```
Ranges of ports may be specified as 1-4 = 1,2,3,4. All may also be used.
```

Any port may be referred to by either Port Numbers or Port Names. All ports with identical port names will be turned off together (as a Port Group)

- The keyword "all" is a valid argument

Examples:

- Set Box 1, Ports 5 & 7 OFF **off 1 5,7**
- Set all boxes, ports 1 through 5, OFF **off 0 1-5**
- If Ports 1, 4 and 8 are named "SUN" in Box #2, then: **off 2 SUN**
 set ports 1, 4 & 8 OFF in Box #2.

on – Turn a Port On

The on command is used to turn on a port or group of ports. If multiple ports are turned on in one command the turn on time is staggered by rbdelay value to each port.

```
PDU 4/4> help on
```

```
Syntax: on <b> <p>
```

```
Description: Turn an outlet or group of outlets on.
```

```
<b> = (box # | all)  <d> = disable  <dly> = delay  <e> = enable
```

```
<n> = name  <t> = time  <p> = (port # | name | all)
```

```
Ports and Boxes may be referred to by all, name (implying a group) or number.
```

```
Ranges of ports may be specified as 1-4 = 1,2,3,4. All may also be used.
```

Any port may be referred to by either Port Numbers or Port Names. All ports with identical port names will be turned on together (as a Port Group)

- The keyword “all” is a valid argument

Examples:

- Set Box 1, Ports 5 & 7 ON **on 1 5,7**
- Set all boxes, ports 1 through 5, ON **on 0 1-5**
- If Ports 1, 4 and 8 are named “SUN” in Box #2, then: **on 2 SUN**
sets ports 1, 4 & 8 ON in Box #2.

***In order to limit current surges, each port is turned on at rbdelay second intervals. The first port in a sequence would turn on immediately; the next would wait until its rbdelay had expired before turning on an so on.

passwd - Change Password

The factory password of “pass” can be changed to any string of **1 to 16 characters** (including all printable characters), not including ‘space’ or ‘comma’, and the new password must not start with a number.

```
PDU 4/4> help passwd
```

```
Syntax: passwd
```

```
Description: Change the log in password.
```

```
<b> = (box # | all)  <d> = disable  <dly> = delay  <e> = enable
```

```
<n> = name  <t> = time  <p> = (port # | name | all)
```

```
PDU 4/4> passwd
```

```
Password: ***
```

```
Re-enter password: ***
```

reboot - Reboot Output

The Reboot Output command is used to turn a port or ports off and then back on. The purpose is to 'reboot' a server or device by cycling the power off and on. Ports that are currently off will be turned on. Ports that are currently on will be turned off and then back on. The Reboot Time duration for each port is assigned in the rbdelay Reboot Delay Time option.

Any Port may be referred to by either Port Numbers or Port Names. All ports with identical port names will be rebooted together (i.e., a Port Group)

- The keyword "all" is a valid argument

```
PDU 4/4> help reboot
```

```
Syntax: reboot <b> <p>
```

```
Description: Reboot an outlet or group of outlets.
```

```
<b> = (box # | all) <d> = disable <dly> = delay <e> = enable
```

```
<n> = name <t> = time <p> = (port # | name | all)
```

```
Ports and Boxes may be referred to by all, name (implying a group) or number.
```

```
Ranges of ports may be specified as 1-4 = 1,2,3,4. All may also be used.
```

Examples:

- Reboot Box 1, Port 8 **reboot 1 8**
- Reboot Box 1, Ports 1, 5, and 7 **reboot 1 1,5,7**
- Cycle all outputs OFF/ON in Box #1 **reboot 1 all**
- If Ports 1,2,3 in Box 2 are defined as "SUN2",
then to Reboot ports 1,2,3 in box 2 **reboot 2 SUN2**
- Reboot all outputs in all boxes. **reboot 0 all**

***If any of the selected ports are already On, they will be power cycled off, then after a delay, back "ON" or if any of the selected ports are Off they will be power cycled "ON".

rbdelay - Set Reboot Time

The reboot delay command sets the time duration that a Port will remain Off before turning back On, after issuing a **Reboot** Command to the PDU 4/4. The Time duration is adjustable from 1 to 29 seconds; each Port may be individually programmed.

```
PDU 4/4> help rbdelay
```

```
Syntax: rbdelay <b> <p> <time>
```

```
Description: Time (1 to 29 seconds) an outlet remains off before turning back on.
```

```
<b> = (box # | all) <d> = disable <dly> = delay <e> = enable
```

```
<n> = name <t> = time <p> = (port # | name | all)
```

```
Ports and Boxes may be referred to by all, name (implying a group) or number.
```

```
Ranges of ports may be specified as 1-4 = 1,2,3,4. All may also be used.
```

status - Display Port Status

Using the **status** command, the user can get a snapshot report of the status of each port.

```
PDU 4/4> help status
Syntax: status <b>
Description: Display outlet status for all connected PDU8(s)

<b> = (box # | all)  <d> = disable  <dly> = delay  <e> = enable
<n> = name  <t> = time  <p> = (port # | name | all)

PDU 4/4> status 1

Box Number 1
Button function is Enabled
Temperature is 26 degrees C
Output Name          Status Delay Current (mA)
1   Port1            OFF  12   0mA
2   Port2            OFF  12   0mA
3   Port3            OFF  12   0mA
4   Port4            OFF  12   0mA
5   Port5            OFF  12   0mA
6   Port6            OFF  12   0mA
7   Port7            OFF  12   0mA
8   Port8            OFF  12   0mA
Bank 1 Current Approx. mA (15A Max.)=0
Bank 2 Current Approx. mA (15A Max.)=0
OK
```

Part 3: Safety Requirements

Symbols found on the product

Markings and labels on the product follow industry-standard conventions. Regulatory markings found on the products comply with requirements.

Regulatory Compliance

Thinklogical™ products are designed and made in the U.S.A. Products have been tested by a nationally recognized testing laboratory and found to be compliant with the following standards (both domestic USA and many international locations).

North America

These products comply with the following standards:

Safety

ANSI/UL60950-1: 1st Edition (2003)

CAN/CSA C22.2 No. 60950-1-03

Electromagnetic Interference

FCC CFR47, Part 15, Class 1

Industry Canada ICES-003 Issue 2, Revision 1

Australia & New Zealand

This is a Class 1 product. In a domestic environment this product may cause radio interference, in which case the user may be required to take adequate measures.

European Union

Declaration of Conformity

Manufacturer's Name & Address: **Thinklogical™**
100 Washington Street
Milford, Connecticut 06460 USA
Telephone (203) 647-8700

Product Name

Model: Power Distribution Unit (PDU) 4/4

thinklogical™

These products comply with the requirements of the Low Voltage Directive 72/23/EEC and the EMC Directive 89/336/EEC.

Standards with Which Our Products Comply

Safety

CENELEC EN 60950-1, (2006)

Electromagnetic Emissions

EN55022: 1994 (IEC/CSP1R22: 1993)

EN61000-3-2/A14: 2000

EN61000-3-3: 1994

Electromagnetic Immunity

EN55024: 1998 Information Technology Equipment-Immunity Characteristics

EN61000-4-2: 1995 Electro-Static Discharge Test

EN61000-4-3: 1996 Radiated Immunity Field Test

EN61000-4-4: 1995 Electrical Fast Transient Test

EN61000-4-5: 1995 Power Supply Surge Test

EN61000-4-6: 1996 Conducted Immunity Test

EN61000-4-8: 1993 Magnetic Field Test

EN61000-4-11: 1994 Voltage Dips & Interrupts Test

Supplementary Information

The following statements may be appropriate for certain geographical regions and might not apply to your location.

This Class A digital apparatus meets all requirements of the Canadian Interference-Causing Equipment Regulations.

Cet appareil numérique de la classe A respecte toutes les exigences du Règlement sur le matériel brouilleur du Canada.



Warning! This is a Class A product. In a domestic environment, this product may cause radio interference, in which case the user may be required to take adequate measures.



Note: This equipment has been tested and found to comply with the limits for a Class A digital device, pursuant to part 15 of the FCC Rules. These limits are designed to provide reasonable protection against harmful interference when the equipment is operated in a commercial environment. This equipment generates, uses and can radiate radio frequency energy and, if not installed and used in accordance with the instruction manual, may cause harmful interference to radio communications in which case the user may be required to take adequate corrective measures at their own expense.



Note: This Class A digital apparatus complies with Canadian ICES-003 and has been verified as being compliant within the Class A limits of the FCC Radio Frequency Device Rules (FCC Title 47, Part 15, Subpart B CLASS A), measured to CISPR 22: 1993 limits and methods of measurement of Radio Disturbance Characteristics of Information Technology Equipment.



Note: The user may notice degraded audio performance in the presence of electromagnetic fields.



Note: If using a keyboard that is noise susceptible, a ferrite ring on the keyboard cable may be needed to comply with Immunity Requirements

Product Serial Number

Thinklogical™ products have a unique serial number, imprinted on an adhesive label that is fixed to the bottom of the chassis. The serial number includes a date-code. The format for the date-code is 2 digits for the month, 2 digits for the day and 2 digits for the year, plus two or three digits for a unique unit number. This serial number is also found on the original shipping carton.

Connection to the Product

Connections and installation hardware for our products use industry-standard devices and methods. All wiring connections to the customer equipment are designed to minimize proprietary or customized connectors and cabling. Power connections are made with regionally appropriate power cords and approved methods.



Part 4: Thinklogical™ Support

Customer Support

Thank you for choosing a Thinklogical™ product for your application. We appreciate your business and are dedicated to helping you successfully use our product. Thinklogical™ is here to help you.

Thinklogical™ is an engineering company and you will receive the information you require directly from our most knowledgeable engineers. We believe that the first line of support is the design engineer that developed the product. Therefore, your questions will be handled promptly by our in-house engineers who are most familiar with your products.

To contact Thinklogical™, use the following telephone numbers and internet-based methods.

Website

Check out our website for current product offerings, support information and general information about all of the products we offer.

Our internet website offers product information on all current systems, including technical specification sheets and installation guides (for viewing online or for download), product diagrams showing physical connections and other information you might need.

Internet: www.thinklogical.com



Note: Most online documents are stored as Adobe Acrobat “PDF” files. If you do not have the Adobe Acrobat reader needed to view PDF files, visit www.adobe.com for a download.

Email

Thinklogical™ is staffed Monday through Friday from 8:30am to 5:00pm, Eastern Time Zone. We will try to respond to your email inquiries promptly, use the following email addresses for your different needs:

info@thinklogical.com – Information on Thinklogical™ and our products.

sales@thinklogical.com – Sales Department - orders, questions or issues.

support@thinklogical.com – Product support, technical issues or questions, product repairs and request for Return Authorization.

Telephone

Telephone Sales: Contact our expert, technically oriented sales staff via telephone in Milford, CT at **(203) 647-8700** or if in the continental US, you may use our **toll-free number (800) 291-3211**. We are here Monday through Friday from 8:30am to 5:00pm, Eastern Time Zone. Ask for their direct dial phone number when you call.

Telephone Product Support: Contact Product Support via telephone in Milford, CT at **(203) 647-8700**. The support lines are manned Monday through Friday, 8:30am to 5:00pm, Eastern Time Zone.

International Sales: Please contact our US sales staff in Milford, CT at **(203) 647-8700**. We are here Monday through Friday, 8:30am to 5:00pm, Eastern Time Zone (same as New York City). If leaving a voice message, please provide a “best time to call back” so we may reach you at your convenience.

Our switchboard attendant will direct your call during regular business hours. We have an automated attendant answering our main telephone switchboard after regular business hours and holidays. You can leave voice messages for individuals at any time. Our Sales Representatives have direct numbers to speed up your next call to us.

Fax

Our company facsimile number is **(203) 783-9949**. Please indicate the nature of the fax on your cover sheet and provide return contact information.

Product Support

Thinklogical's™ support personnel are available Monday through Friday from 8:30am to 5:00pm, Eastern Time Zone. If your application might require assistance at some time outside of our normal business hours, please contact us beforehand and we will do our best to make arrangements to help you with your Thinklogical™ products.

Warranty

Thinklogical, LLC (“Thinklogical”) warrants this product against defects in materials and workmanship for a period of one (1) year from the date of delivery (ordinary wear and tear excluded). This limited warranty does not cover defects resulting from (i) use of the product other than as described in the applicable documentation for the product; (ii) modifications to or repairs of the product that are made by any party other than Thinklogical or a party acting on Thinklogical's behalf, or (iii) combination of the product with third party products that is not consented to by Thinklogical. Occurrences of events described in (i) – (iii) shall void the foregoing warranty. This warranty gives you specific legal rights, and you may also have other rights which vary from state to state.

Except for the express warranty set forth above, to the fullest extent permitted under applicable law, Thinklogical, LLC and its suppliers disclaim any and all other warranties, express and implied, including without limitation the implied warranties of merchantability, fitness for a particular purpose, title and non-infringement.

If the defective product is returned to the authorized dealer within one (1) year of the delivery date, repair or replacement of the product will be made. Repairs may be made with refurbished parts. If

thinklogical™

repair or replacement is not possible, Thinklogical may keep the defective product and refund the amount that you paid for the defective product. These are Thinklogical's sole obligations, and your exclusive remedies, for a breach of the limited warranty set forth above.

To return a defective product, contact the Thinklogical authorized dealer from whom you purchased the product. Do not return a product directly to Thinklogical without prior authorization from your dealer.

If you have received prior authorization from your dealer and are returning a product directly to Thinklogical:

1. Contact your sales representative, or call Customer Support at (800)291-3211 or + (203)647-8700.
2. Describe the defect with the product and Customer Support will issue a Return Merchandise Authorization Number (RMA#).
3. Pack the product in all of its original packing, if possible, and write the RMA number on the box.
4. Return the product to:
Thinklogical, LLC
Attn: RMA# [Insert the RMA# issued to you, by Thinklogical, here.]
100 Washington Street
Milford, CT 06460 USA

Our Address

If you have any issue with the product, have product questions or need technical assistance with your Thinklogical™ system, please call us at **800-291-3211 (USA only)** or **(203) 647-8700** and let us help. If you'd like to write us, our mailing address is:

**Thinklogical™ Inc.
100 Washington Street
Milford, CT 06460 USA**

Appendix A: Ordering Information

| Thinklogical's Power Distribution Unit 4/4 | |
|---|---|
| Part Number | Description |
| PDU-000001 | PDU 4/4, Power Distribution Unit, Domestic, Serial Interface |
| | |

Appendix B: Quickstart Guide

PDU 4/4 QUICK START GUIDE

Thinklogical's™ PDU 4/4 Power Distribution Unit is an AC Power Switch that provides the ability to remotely control the power to up to eight devices per unit. It gives system administrators the capability to restart a "locked up" network device from an RS-232 Serial Port. The PDU 4/4 provides eight individually-controlled AC power outlets that are switched off and on as desired. The PDU 4/4 communicates with its control terminal using a serial interface. The easy-to-use PDU 4/4 provides control to all devices with simple commands to turn Power Off or On to reboot any one port, multiple ports, port groups or all devices. Power restraints can be sequenced using programmed time delays to minimize surge or allow drive spin-up time. Rear panel LEDs display the status of each port.

Your configuration can be easily expanded with a serial cable for each PDU 4/4 unit added. A single serial interface integrates the control of all PDU 4/4s in your application. Up to sixteen PDU 4/4s can be cascaded together to control multiple systems from one common user interface. Each PDU 4/4 utilizes two banks of four outlets. Each outlet individually switches up to 10 Amperes maximum with each bank rated at 15 Amperes total. The PDU 4/4 is designed for rack mounting (1U) or as a desktop device.

Each PDU4/4 system includes the following features:

- Eight individually-controlled AC power outlets
- Dual 15 Amp (max) circuits, four outlets per circuit
- Redundant DC power supplies for built-in I/O and control circuits
- Individually programmable Reboot Time Delay on each outlet
- Solid state zero-crossing relays to minimize power spikes
- Easily expandable configuration
- Password Security
- User-definable Port Names and Port Groups
- Front panel display for easy system set up and configuration
- Current monitoring of each port to determine if connected unit turns on.
- Software updates available on ftp.thinklogical.com

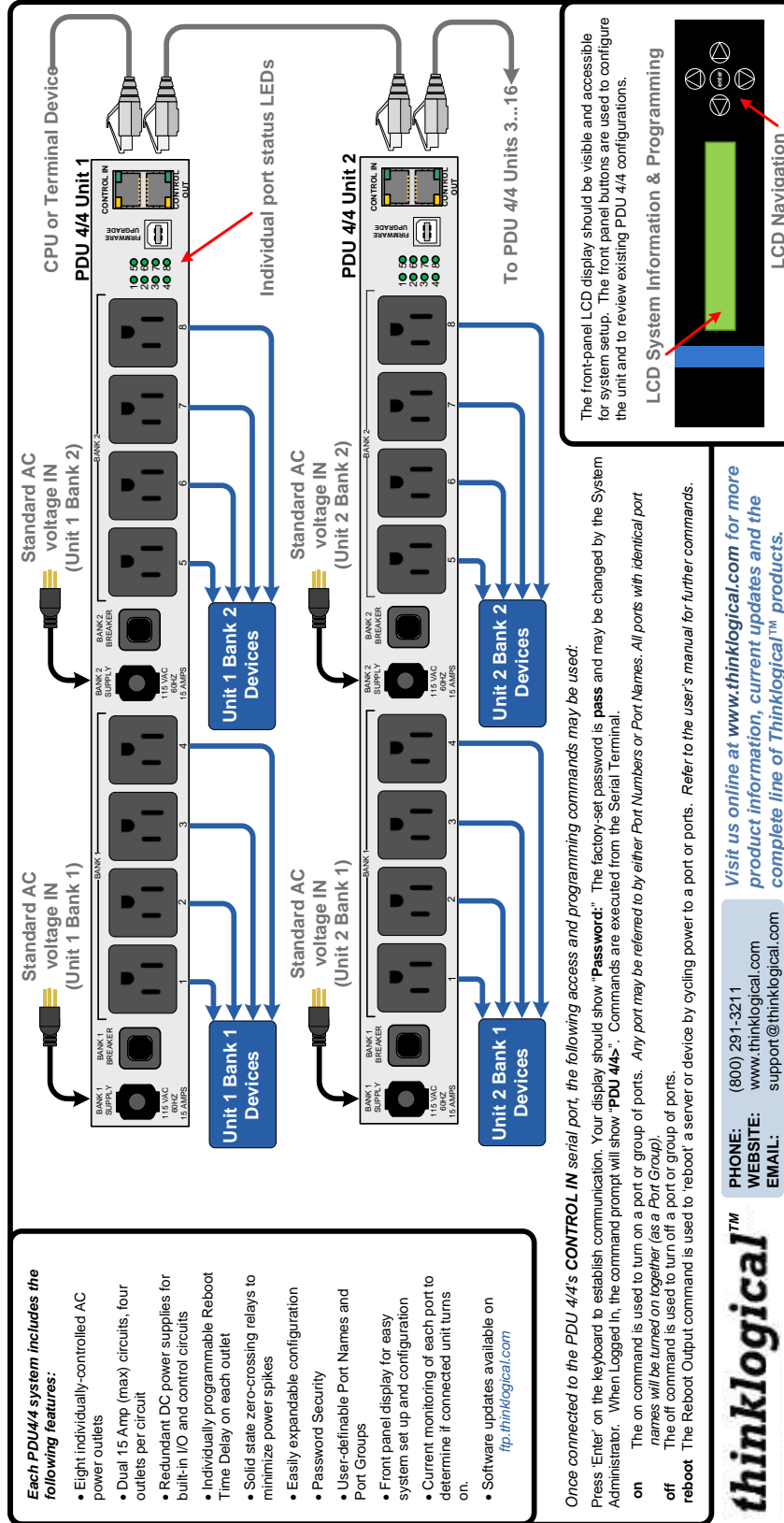

Once connected to the PDU 4/4's CONTROL IN serial port, the following access and programming commands may be used:
Press 'Enter' on the keyboard to establish communication. Your display should show "Password". The factory-set password is **pass** and may be changed by the System Administrator. When Logged In, the command prompt will show "PDU 4/4s". Commands are executed from the Serial Terminal.

on The on command is used to turn on a port or group of ports. Any port may be referred to by either Port Numbers or Port Names. All ports with identical port names will be turned on together (as a Port Group).
off The off command is used to turn off a port or group of ports.
reboot The Reboot Output command is used to 'reboot' a server or device by cycling power to a port or ports. Refer to the user's manual for further commands.

thinklogical™

PHONE: (800) 291-3211
WEBSITE: www.thinklogical.com
EMAIL: support@thinklogical.com

Visit us online at www.thinklogical.com for more product information, current updates and the complete line of Thinklogical™ products.