

StudioPRO Extender

Single-Link and Dual-Link Fiber Optic
Digital Video Extension Systems

PRODUCT MANUAL

Thinklogical™ Inc.
100 Washington Street
Milford, Connecticut 06460 U.S.A.
Telephone 1-203-647-8700
Fax 1-203-783-9949
www.thinklogical.com

thinklogicaltm

Copyright Notice

Copyright © 2010. All rights reserved. Printed in the U.S.A.

Thinklogical[™], a subsidiary of *Logical Solutions*[™], Inc.

100 Washington Street

Milford, Connecticut, U.S.A. 06460

Telephone 1-203-647-8700

All trademarks and service marks are property of their respective owners.

Powered by
MRTS Technology

Subject: DCS StudioPRO Extender Product Manual

Revision: C, January 2010

Table of Contents

1.	Introduction	1
1.1.	Application.....	1
1.2.	Increased Security and Efficiency.....	1
1.3.	Laser Information.....	1
2.	System Features.....	3
2.1.	General System Features.....	3
2.2.	Hardware Features.....	3
2.2.1.	Transmitter Front and Back Panels.....	4
2.2.2.	Receiver Front and Back Panels.....	4
2.3.	Technical Specifications	5
3.	Connecting the SPE System	7
3.1.	Overview.....	7
3.2.	Contents	7
3.3.	Order of Installation Events	8
3.3.1.	Fiber Optic Cables.....	8
3.3.2.	Digital Video Interface (DVI-D) Input - Transmitter	8
3.3.3.	Digital Video Interface (DVI-D) Output - Receiver	9
3.3.4.	USB Type B - Transmitter	9
3.3.5.	USB Type A - Receiver	9
3.3.6.	AC Power Supply	9
3.4.	Status LEDs.....	10
3.4.1.	Transmitter	10
3.4.2.	Receiver	11
3.5.	General Button Usage – DDC Select	12
3.5.1.	Operation of the DDC Modes	12
4.	Regulatory and Safety Requirements.....	14
4.1.	Safety Requirements	14
4.1.1.	Symbols Found on the Product	14
4.1.2.	Product Serial Number	14
4.1.3.	Industry-Standard Connections to the Product.....	14
4.2.	Regulatory Compliance	14
4.2.1.	North America	15
4.2.2.	Australia & New Zealand	15
4.2.3.	European Union	15
4.2.4.	Product Standards Compliance.....	15
4.3.	Supplementary Information.....	16
5.	How to Contact Us.....	17
5.1.	Customer Support	17
5.1.1.	Website	17
5.1.2.	Email	17
5.1.3.	Telephone	17
5.1.4.	Fax	18

5.2. Product Support..... 18

 5.2.1. Warranty..... 18

 5.2.2. Our Address 18

Appendix A: StudioPRO Extender™ Models..... 19

Appendix B: SPE Enclosure Dimensions 20

Appendix C: SPE Quick Start Guides 21

1. Introduction

1.1. Application

Powered by Thinklogical'sTM cutting edge, patent-pending MRTS (**M**ulti **R**ate **T**ransmission **S**ystem) Technology, our StudioPRO Extender (SPE) DVI Extension System transports every frame of a DVI video stream seamlessly with no compression or dropped frames. In addition, all high speed peripherals function with no latency. Utilizing standard SFP+ transceivers the system uses multi-mode or single-mode fiber optic cable to permit the placement of a digital monitor or projector up to 1000 meters (3280 feet) away from the controlling computer without loss of resolution. Using single-mode SFP+ modules and fiber optic cable, distances up to 40km can be achieved. Installation is plug-and-play and no adjustments are necessary.

Comprised of two compact units, the SPE **transmitter** connects to the host computer with standard USB and DVI cables and the **receiver** provides four ports for connection of peripheral devices as well as video connections. External power is required for both the transmitter and receiver units and two universal AC to 5VDC power supplies are included. In addition, indicator LEDs provide link performance status at a glance.

The SPE successfully and effectively delivers DVI and USB peripherals when and where you need them.

1.2 Increased Security and Efficiency

The ability to locate the CPU remotely from the monitor and peripherals allows full control of the computer environment. It is now possible to position the monitor or projector in any setting from office to lecture hall to boardroom while keeping the computer secure in a controlled location.

1.3 Laser Information

All **StudioPRO Extender** models are designed and identified as **Class 1 LASER products**.

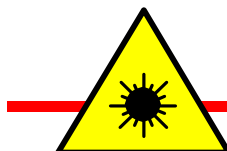

CLASS 1 LASERS do not require any special precautions under conditions of normal use.

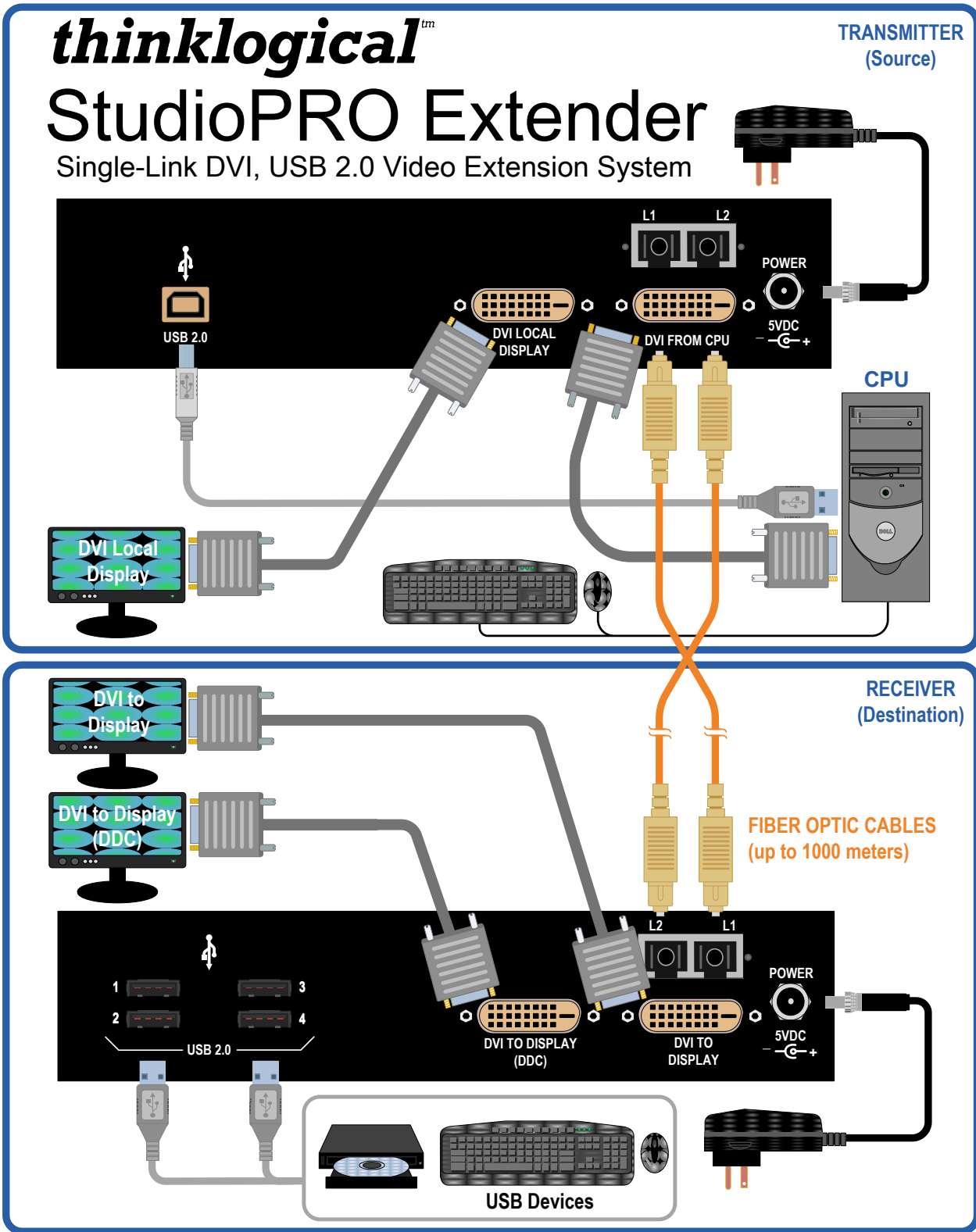

Figure 1: StudioPRO Extender, Single-Link application

2 System Features

2.1 General System Features

The SPE systems are designed for high-resolution video and USB extension applications such as remote projection centers, theaters and assembly halls, and for secure computer installations. The ability to remotely locate the CPU away from the monitor and peripherals allow full control of your computer environment. It is now possible to position your monitor or projector in any setting from office to lecture hall to boardroom while keeping the computer secure in a remote, controlled location.

- Installation is Plug-and-Play: No adjustments are necessary
- Supports USB 2.0 hi-speed devices
- Available with multi-mode or single-mode optics
- Indicator LEDs provide link performance status
- Available with your choice of ST, SC or LC fiber connectors*
- Single-link DVI model supports all single-link video resolutions
- Dual-link DVI model supports all single-link and dual-link video resolutions
- Support of the DVI-D interface
- Fully DDC2B compliant
- Transparent operation and functionality - no user interaction required
- Signal transmission via fiber optic cable - no RF interference
- Supports HDCP at distances up to 300 meters

**Single-mode uses SC APC-type or LC-type connectors.*

2.2 Hardware Features

The SPE systems are self-contained and do not require user modifications. Once installed, the application delivers video and USB signals clearly and consistently.

- Enclosed metal chassis for each Transmitter and Receiver unit
- One pair of extenders per video connection
- DVI-D port for digital video signal connection
- Two universal AC to 5VDC power adapters provided with each SPE System

2.2.1 Transmitter Front and Back Panels

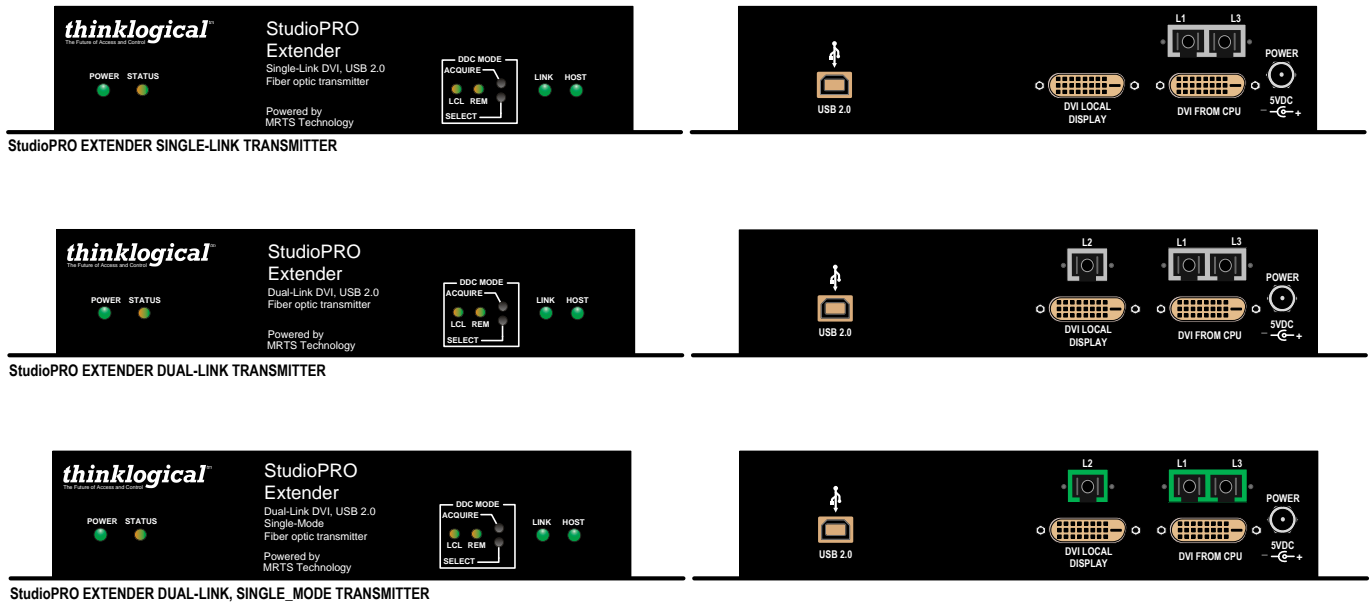

Figure 2: Front and Back Views of the SPE Transmitter Models

2.2.2 Receiver Front and Back Panels

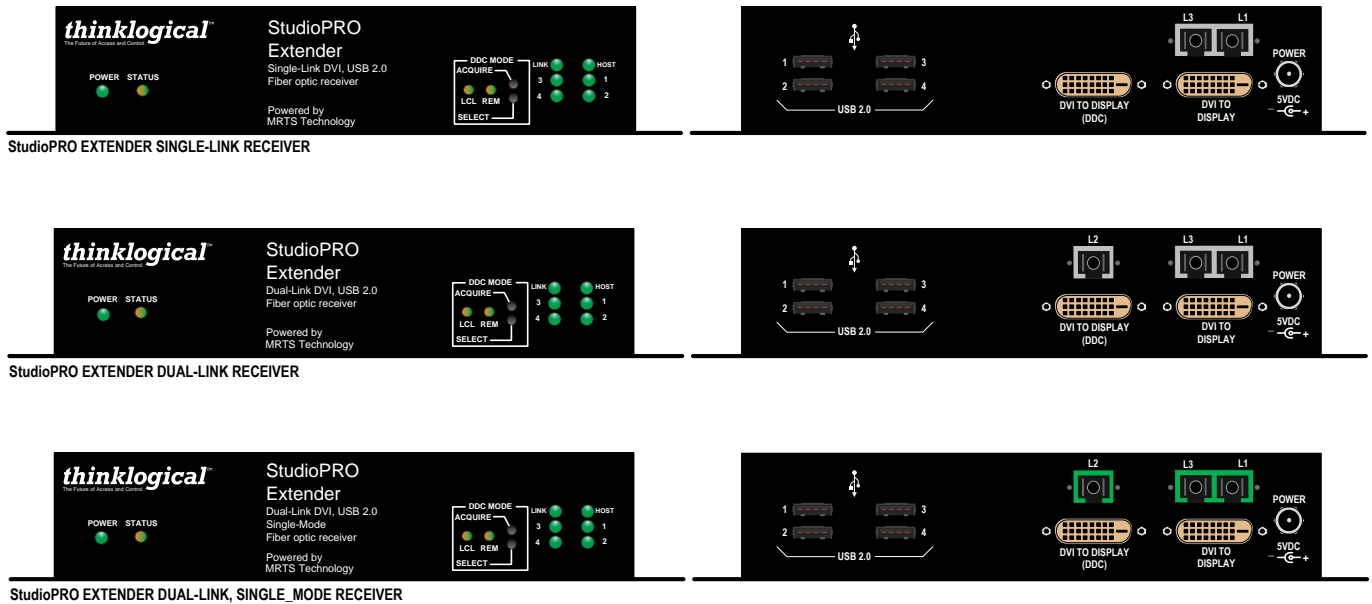

Figure 3: Front and Back Views of the SPE Receiver Models

2.3 Technical Specifications

Each Thinklogical StudioPRO Extender SystemTM is designed to the following specifications:

Electrical Cables (supplied with system)	USB Type A to USB Type B Cable, 6FT (1) DVI-D Male to DVI-D Male Cable, 2M (Single Link Model Only) (1) DVI-D Male to DVI-D Male Dual-Link Cable, 2M (Dual Link Model Only) (1)
Connectors	<p>Single-Link Receiver: DVI-D female video output (2) Fiber connectors (2) USB-A connectors (4) DC Power jack (AC adapter provided) (1)</p> <p>Dual-Link Receiver: DVI-D female video output (2) Fiber connectors (3) USB-A connectors (4) DC Power jack (AC adapter provided) (1)</p> <p>Single-Link Transmitter: DVI-D female video input (1) DVI-D female video output (1) Fiber connectors (2) USB-B connector (1) DC Power jack (AC adapter provided) (1)</p> <p>Dual-Link Transmitter: DVI-D female video input (1) DVI-D female video output (1) Fiber connectors (3) USB-B connectors (1) DC Power jack (AC adapter provided) (1)</p>
DDC Protocol	Full DDC2B compliant
Optical Budget	>6 dB multi-mode; >15 dB single-mode 40km optics; >8 dB single-mode 10km optics
Laser Output Specifications	Transmitter and Receiver lasers meet Class 1 Laser specifications. <i>(Class 1 lasers do not require any special precautions under conditions of normal use.)</i>

Optical Cables	<p>Single-Link: L1: Data Tx to Rx and Video L2: Data Rx to Tx</p> <p>Dual-Link: L1: Data Tx to Rx and Video (Primary) L2: Data Rx to Tx L3: Video (Secondary)</p> <p>Fiber is either multi-mode, 50 micron or 62.5 micron with ST-, SC- or LC-type connectors or single-mode with SC APC-type or LC-type connectors.* (Fiber cable is either customer-supplied or can be ordered from Thinklogical™.)</p>
Fiber Distances	<p>Up to 350 meters using type OM2 (5/125µm) Up to 650 meters using type OM3 enhanced (5/125µm) Up to 1000 meters using type OM4 (5/125µm) Up to 10 kilometers using type (9/125µm)</p>
*Optical Couplant	<p><i>For use with Single-Mode models with LC-Type connectors only.</i> A syringe pre-loaded with optical coupling gel is included. Applied to the connector end face to reduce the difference in the index of refraction and Fresnel reflections at the interface of the mated connectors.</p>
Operating Temperature and Humidity	<p>0 to 50 °C (32 to 122 °F), 5 to 95% RH, non-condensing</p>
Housing Dimensions	<p>7.875" W x 6.625" D x 1.75" H (200.02 mm x 168.27 mm x 44.45 mm)</p> <p>With mounting brackets: 9.00" W x 6.625" D x 1.75" H (228.60 mm x 168.27 mm x 44.45 mm)</p> <p>Wall-mount keyhole slot spacing: 8.50" W x 5.75" D (215.90 mm x 146.05 mm)</p>
Supply Voltage	<p>Input: AC 100-240V @ 50/60Hz 0.55A Output: +5.0 VDC @ 4 A</p>

3 Connecting the SPE System

3.1 Overview

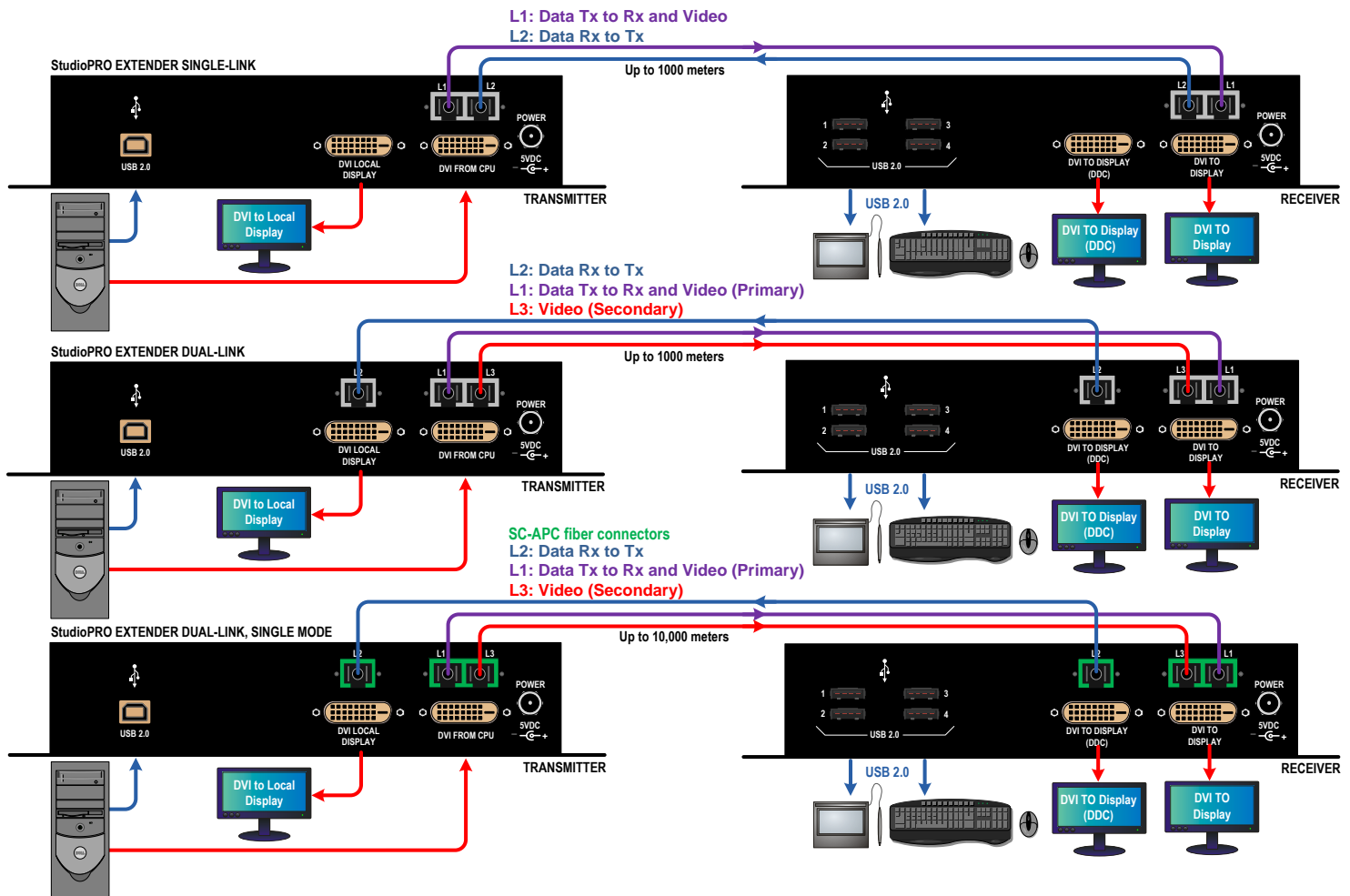

Figure 4: SPE Connections by model

3.2 Contents

When you receive your Thinklogical StudioPRO Extender System™, you should find the following items:

- StudioPRO Extender™ Transmitter
- StudioPRO Extender™ Receiver
- AC Power Supply (PWR-000022-R) – (2)
- USB Cable, 6 Feet
- DVI-D (M to M) Video Cable, 2 Meters
- StudioPRO Extender™ Product manual (CD)
- Optical gel where applicable

All physical connections to the product use industry-standard connectors.

3.3 Order of Installation Events

Refer to the **SPE Quick Start Guides** included in **Appendix C** on **pages 21-24** for detailed installation instructions.

3.3.1 Fiber Optic Cables

Fiber Optic cables for the SPE system are not included but are available commercially or through ThinklogicalTM. Please contact your ThinklogicalTM sales representative for a quotation on your required cable length or call us at **1-800-291-3211**.

Two to three fiber optic cables must be run between the location of the SPE Transmitter (at the CPU or other DVI-D video source) and the SPE Receiver (monitor, projector, etc.). The standard multi-mode fiber cable must be 50 micron, terminated with an LC, SC, or ST-type connector. Single-mode fiber optic cables with SC APC- or LC-type connectors are available. Be careful to not kink or pinch the fiber cable as it is being installed and keep all bend radii to no less than 3 inches. Connect your fiber cables (L1Tx to L1Rx, L2Tx to L2Rx, etc.) to the fiber connectors on each pair of SPE Transmitters and Receivers and dress the cable to prevent crushing, pinching or other damage.



Figure 5: *Fiber Optic Cable with ST and LC-Type connectors*

3.3.2 Digital Video Interface (DVI-D) Input – Transmitter

The SPE Transmitter connects to your DVI video source (DVI-D video card) using the provided DVI-D male-to-male cable (CBL000009-002MR). **The Digital Video Interface connector on the transmitter will not accept other DVI connectors such as DVI-I or DVI-A.**

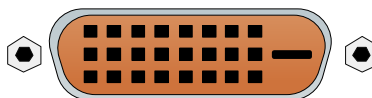

Figure 6: *DVI-D (Digital Video Interface) Connector*

3.3.3 Digital Video Interface (DVI-D) Output - Receiver

The SPE Receiver unit connects to your DVI-D video monitor, projector, or other viewing device at the remote destination. Your device must have a DVI-D connector.

3.3.4 USB Type B – Transmitter

Connect your PC's USB-A port to the Transmitter's USB-B port using the provided USB A to B Cable (CBL000015-006FR). The USB-B port is located on the rear panel of the Transmitter unit.



Figure 7: *USB Type B port and connector*

3.3.5 USB Type A – Receiver

Using the cables on your USB device, connect up to four devices to any of the USB- A ports located on the rear panel of the Receiver unit.



Figure 8: *USB Type A port and connector*

3.3.6 AC Power Supply

Two separate wall-pack AC to 5VDC power supplies (PWR-000022-R) are included. A power jack located on the rear panel of the transmitter and receiver units accepts the 5VDC input.

POWER SUPPLY SPECIFICATIONS

- Universal Input: 100-240 VAC 50/60Hz Nominal
- Continuous Short Circuit Protection
- Over Voltage Protection
- Conductive EMI Meets CISPR/FCC Class B high efficiency, 75% Typical
- AC Plug is adaptable



Figure 9: *AC to 5VDC Power Supply (PN: PWR-000022-R) with optional AC adapters*

3.4 Status LEDs

3.4.1 Transmitter

Indicator LEDs	Status
DDC MODE: Pass-Thru	Local LED is GREEN & Remote LED is GREEN: Acts as a direct connection between CPU and display. No emulation is performed.
DDC MODE: Remote Dynamic	Local LED is OFF & Remote LED is Green: EDID is read from the remote display and is updated each time the remote display changes.
DDC MODE: Remote Static	Local LED is ORANGE & Remote LED is Green: EDID is read from the remote display when the acquire button is pressed.
DDC MODE: Local Static	Local LED is GREEN & Remote LED is ORANGE: EDID is read from the local display when the acquire button is pressed.
POWER	GREEN LED is ON when power is connected.
USB LINK	GREEN LED is ON when the Power, device port(s), and Fibers are properly connected. GREEN LED is BLINKING when the fibers are properly connected and the Host is busy enumerating.
USB HOST	GREEN LED is ON when the computer establishes a USB connection.
TX Status LED (Near the Power LED)	The status LED indicates the connection status of the TX Extender.
	GREEN: Fiber L2 is connected and a good link is established
	ORANGE: Local Static Mode selected and no fiber link from RX to TX (L2 is not connected), or both buttons are held down and the unit is waiting to reload the default DDC table.
	RED Flashing: No Fiber Link from RX to TX (Not available in Local Static mode).

3.4.2 Receiver

Indicator LEDs	Status
DDC MODE: Pass-Thru	Local LED is GREEN & Remote LED is GREEN: Acts as a direct connection between CPU and display. No emulation is performed.
DDC MODE: Remote Dynamic	Local LED is OFF & Remote LED is Green: EDID is read from the remote display and is updated each time the remote display changes.
DDC MODE: Remote Static	Local LED is ORANGE & Remote LED is Green: EDID is read from the remote display when the acquire button is pressed.
DDC MODE: Local Static	Local LED is GREEN & Remote LED is ORANGE: EDID is read from the local display when the acquire button is pressed.
POWER	GREEN LED is ON when power is connected.
LINK	Shows the status of connections: GREEN LED is ON when the Power, device port(s), and Fibers are properly connected. GREEN LED is BLINKING when the fibers are properly connected and while the Host is enumerating.
HOST	GREEN LED is ON when the computer establishes a USB connection.
1, 2, 3, 4	GREEN LED is ON: Indicates an established connection to USB-A Port 1, 2, 3 and/or 4.
RX Status LED (Near the Power LED)	The status LED indicates the connection status of the RX Extender.
	GREEN: Good Link and DVI monitor connected to primary port (port on left looking at DVI connectors).
	ORANGE: No DVI monitor connected to primary port.
	RED Flashing: No Fiber Link from TX to RX (L1 is not connected).

3.5 General Button Usage – DDC Select

The TX and RX units both have a button labeled DDC SELECT. When the data communications fibers L1 and L2 are connected, either unit will control the state of the DDC operation. Each press of the button will advance the DDC state from PASS THRU to DYNAMIC to STATIC and back to PASS THRU. (Because the buttons are small, a firm, fine-tipped device such as a mechanical pencil tip or tweezers may work best). When the units are disconnected, the DDC state of the TX unit is the master and will be sent to the RX when data communications are restored.

- In PASS THRU mode, the CPU communicates directly with the connected monitor for DDC information.
- In DYNAMIC mode the DDC of the monitor is read from the receiver and stored in the transmitter.
- In STATIC mode the DDC information in the transmitter is not changed regardless of changes made at the receiver end.

There is also a **DEFAULT DDC TABLE** stored in the device. This table is suitable for use with many standard PC monitors. **THE DEFAULT DDC TABLE CAN ONLY BE LOADED FROM THE TX.**

If you wish to restore the Default DDC Table to the product and automatically place the device into STATIC DDC mode, hold both buttons down for approximately 7 seconds or until you see the DDC mode LEDs change to Remote Static Mode (LCL LED=Orange and REM LED=Green).

3.5.1 Operation of the DDC Modes

DDC (Display Data Channel) is a VESA standard communications channel between a display adapter and a video monitor. DDC data is stored in a monitor and describes the monitors characteristics (vendor name, serial number, frequency range, analog or digital capabilities, etc.). DDC information is read from the monitor by a video card so the video card can gather **Extended Display Identification Data (EDID)** and provide a video format acceptable to the monitor. (EDID is a VESA standard data structure provided by a computer display to describe its capabilities to a graphics card. It is what enables a personal computer to detect what kind of monitor is connected.)

As the transmitter emulates a monitor it must provide a DDC table to the video card in order for the video card to provide images for transport. Some video cards may turn off video output if the DDC is not present at boot up (missing monitor, hot-plugged or the DDC information does not match expected digital or analog parameters). Some video cards are more tolerant and will produce video output under many conditions. Due to the variability of video card DDC handling, ThinklogicalTM products provide the DDC support modes detailed below.

3.5.1.1 Dynamic Mode

Dynamic DDC mode is the default and recommended mode of DDC operation. In this mode the RX will read the DDC from a monitor under two conditions; during power-up and if the monitor cable is removed and reinstalled. The RX will only read the DDC to RAM (*It will not be stored on the RX*). Once the RX has validated the DDC it informs the TX of a change in DDC information.

Once informed of a DDC change the TX reads the DDC information from the RX. If the DDC from the RX is different from that stored in the TX non-volatile memory, the TX writes the new DDC information to non-volatile memory that the video card can read. The TX then informs the video card that the DDC information has changed so that the video card can read the DDC and act accordingly. In this mode the CPU may be booted up with the TX turned off or disconnected from the RX since the TX non-volatile DDC memory can be read by the video card without TX power.

3.5.1.2 Static Mode

Static DDC mode is typically used in switching situations. In some switching situations the customer may be using multiple monitors that are all capable of handling the same video resolution but some of the monitors in the system may cause the video card to turn off the video output. Another possible use of Static DDC mode is when a video card does not recover from a video cable being hot-plugged while the system is booted. Static mode resolves these issues by preventing the TX from writing to the non-volatile DDC memory stored on the TX and static mode prevents the TX from informing the video card of a change in DDC data. In this mode the CPU may be booted up with the TX off or disconnected from the RX since the TX non-volatile DDC memory can be read by the video card without TX power.

3.5.1.3 Pass Thru DDC Mode

Pass Thru DDC mode gives the video card direct access to the monitor connected to the RX. This mode is useful in HDCP (High-bandwidth Digital Content Protection) applications. In Pass Thru DDC mode the video card can directly *write-to* and *read-from* the monitor. The video card will be informed of the presence or absence of a connected monitor. In this mode there must be a valid data communication path between the CPU and a connected monitor before the CPU can be booted.

When a Thinklogical™ product is supplied to customers it typically comes with a default table that provides a maximum resolution of 1920x1200. If the customer elects to use the default DDC data in static mode, the video card will read that the TX (emulating a monitor) is capable of showing 1920x1200. If the monitor connected at the RX cannot display a resolution as high as 1920x1200 the monitor will not display an image.

4 Regulatory and Safety Requirements

4.1 Safety Requirements

4.1.1 Symbols Found on the Product

Markings and labels on the product follow industry-standard conventions. Regulatory markings found on the products comply with domestic and international requirements.

4.1.1.1 Class 1 LASER Labeling

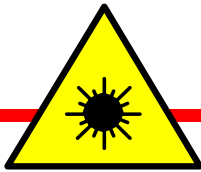

CLASS 1 LASERS do not require any special precautions under conditions of normal use.

4.1.2 Product Serial Number

The SPE products have a unique serial number printed on a small silver label on the bottom of the chassis. The serial number includes a date-code. The format for the date-code is 2-digits for the month, two digits for the day, two digits for the year and two or three digits for a unique unit number. This serial number is also found on the original shipping carton.

4.1.3 Industry-Standard Connections to the Product

Connections and installation hardware for the product use industry-standard devices and methods. All wiring connections to the customer equipment minimize proprietary or customized connectors and cabling. Power connections are made with regionally appropriate power cords and approved methods.

4.2 Regulatory Compliance

ThinklogicalTM SPE products are designed and made in the U.S.A. SPE products have been tested by a nationally certified testing laboratory and found to be compliant with the following standards (both domestic USA and international locations).

4.2.1 North America

These products comply with the following standards:

Safety

- UL60950: 2000
- CAN/CSA C22.2 No. 60950-00

LASER Safety

- CDRH 21CFR 1040.10
- Class 1 LASER Product

Electromagnetic Interference

- FCC CFR47, Part 15, Class A
- Industry Canada ICES-003 Issue 2, Revision 1

4.2.2 Australia & New Zealand

This is a Class A product. In a domestic environment this product may cause radio interference, in which case the user may be required to take adequate measures.

4.2.3 European Union

4.2.3.1 Declaration of Conformity

Manufacturer's Name & Address: **ThinklogicalTM Inc.**
100 Washington Street
Milford, Connecticut 06460 USA
Telephone 1-203-647-8700

Product Name: **StudioPRO USB 2.0 and DVI Extender**

These products comply with the requirements of the Low Voltage Directive 72/23/EEC and the EMC Directive 89/336/EEC.

4.2.4 Product Standards Compliance

Safety

- IEC60950:1992+A1, A2, A3, A4, A11

LASER Safety

- IEC60825-1/2
- Class 1 LASER Product

Electromagnetic Emissions

- EN55022: 1994 (IEC/CSPIR22: 1993)
- EN61000-3-2/A14: 2000
- EN61000-3-3: 1994

Electromagnetic Immunity

- EN55024: 1998 Information Technology Equipment-Immunity Characteristics
- EN61000-4-2: 1995 Electro-Static Discharge Test
- EN61000-4-3: 1996 Radiated Immunity Field Test
- EN61000-4-4: 1995 Electrical Fast Transient Test
- EN61000-4-5: 1995 Power Supply Surge Test
- EN61000-4-6: 1996 Conducted Immunity Test
- EN61000-4-8: 1993 Magnetic Field Test
- EN61000-4-11: 1994 Voltage Dips & Interrupts Test

4.3 Supplementary Information

The following statements may be appropriate for certain geographical regions and might not apply to your location.



NOTE:

This equipment has been tested and found to comply with the limits for a Class A digital device, pursuant to part 15 of the FCC Rules. These limits are designed to provide reasonable protection against harmful interference when the equipment is operated in a commercial environment. This equipment uses, generates and can radiate radio frequency energy and, if not installed and used in accordance with the instruction manual, may cause harmful interference to radio communications. Operation of this equipment in a residential area may cause harmful interference in which case the user may be required to take corrective measures.



NOTE:

This Class A digital apparatus complies with Canadian ICES-003 and has been verified as compliant within the Class A limits of the FCC Radio Frequency Device Rules (FCC Title 47, Part 15, Subpart B CLASS A), measured to CISPR 22: 1993 limits and methods of measurement of Radio Disturbance Characteristics of Information Technology Equipment.



NOTE:

This Class A digital apparatus meets all requirements of the Canadian Interference-Causing Equipment Regulations.

Cet appareil numérique de la classe A respecte toutes les exigences du Règlement sur le matériel brouilleur du Canada.



WARNING!

This is a Class A product. In a domestic environment this product may cause radio interference, in which case the user may be required to take corrective measures.

5 How to Contact Us

5.1 Customer Support

Thank you for choosing ThinklogicalTM products for your application. We appreciate your business and are dedicated to helping you successfully use our products. ThinklogicalTM is always here to help. To contact us please use the following telephone numbers and internet-based methods.

5.1.1 Website

Visit our website for more product information, current updates and the complete line of ThinklogicalTM products.

Our internet website offers product information on all current systems, including technical specification sheets, Quick Start Guides, product diagrams and more. We are continually updating our website, so be sure to refresh your browser when visiting our website to see the most up-to-date information.

Internet: www.thinklogical.com



NOTE:

Most online documents are stored as Adobe Acrobat “PDF” files. If you do not have the Adobe Acrobat reader needed to view PDF files, visit www.adobe.com for a download.

5.1.2 Email

ThinklogicalTM is staffed Monday through Friday from 8:30am to 5:30pm, Eastern Time Zone. We will do our best to respond to your email inquiries promptly. Please use the following email addresses according to your needs:

info@thinklogical.com – Information about ThinklogicalTM and our products.

sales@thinklogical.com – Sales Department - orders, questions or issues.

support@thinklogical.com – Product support, technical issues or questions, product repairs and request for Return Merchandise Authorization.

5.1.3 Telephone

Telephone Sales: Contact our expert sales staff via telephone in Milford, Connecticut at **1-203-647-8700** or, if in the continental US, you may use our toll-free number **1-800-291-3211**. We are here Monday through Friday from 8:30am to 5:30pm, Eastern Time Zone. Ask for your sales representative’s direct dial phone number when you call.

Telephone Product Support: Contact Product Support via telephone in Milford, CT at **1-203-647-8700**. The support lines are manned Monday through Friday, 8:30am to 5:30pm, Eastern Time Zone.

International Sales: Please contact our US sales staff in Milford, CT at **1-203-647-8700**. We are here Monday through Friday, 8:30am to 5:30pm, Eastern Time Zone (same as New York City). If leaving a voice message, please provide a preferred time for us to call back so we can reach you at your convenience.

Our switchboard attendant will direct your call during regular business hours. We have an automated attendant answering our main telephone switchboard after regular business hours and on holidays. You can leave a voice message for an individual at any time. Our Sales Representatives have direct numbers to facilitate your calls to us.

5.1.4 Fax

Our company facsimile number is **1-203-783-9949**. Please indicate the nature of the fax on your cover sheet and provide return contact information.

5.2 Product Support

Thinklogical's™ support personnel are available Monday through Friday from 8:30am to 5:30pm, Eastern Time Zone. If your application might require assistance at some time outside of our normal business hours, please contact us beforehand and we will do our best to make arrangements to help you with your Thinklogical™ products.

5.2.1 Limited Warranty Information

Thinklogical, LLC ("Thinklogical") warrants this product against defects in materials and workmanship for a period of one (1) year from the date of delivery (ordinary wear and tear excluded). This limited warranty does not cover defects resulting from (i) use of the product other than as described in the applicable documentation for the product; (ii) modifications to or repairs of the product that are made by any party other than Thinklogical or a party acting on Thinklogical's behalf, or (iii) combination of the product with third party products that is not consented to by Thinklogical. Occurrences of events described in (i) – (iii) shall void the foregoing warranty. This warranty gives you specific legal rights, and you may also have other rights which vary from state to state.

Except for the express warranty set forth above, to the fullest extent permitted under applicable law, Thinklogical, LLC and its suppliers disclaim any and all other warranties, express and implied, including without limitation the implied warranties of merchantability, fitness for a particular purpose, title and non-infringement.

If the defective product is returned to the authorized dealer within one (1) year of the delivery date, repair or replacement of the product will be made. Repairs may be made with refurbished parts. If repair or replacement is not possible, Thinklogical may keep the defective product and refund the amount that you paid for the defective product. These are Thinklogical's sole obligations, and your exclusive remedies, for a breach of the limited warranty set forth above.

To return a defective product, contact the Thinklogical authorized dealer from whom you purchased the product. Do not return a product directly to Thinklogical without prior authorization from your dealer.

If you have received prior authorization from your dealer and are returning a product directly to Thinklogical:

1. Contact your sales representative, or call Customer Support at (800)291-3211 or + (203)647-8700.
2. Describe the defect with the product and Customer Support will issue a Return Merchandise Authorization Number (RMA#).
3. Pack the product in all of its original packing, if possible, and write the RMA number on the box.
4. Return the product to:
Thinklogical, LLC
Attn: RMA# [Insert the RMA# issued to you, by Thinklogical, here.]
100 Washington Street
Milford, CT 06460 USA

5.2.2 Our Address

If you have any issues with your product, have product questions or need technical assistance, please call us at **1-203-647-8700** and let us help.

If shipping something with an RMA # or if you'd like to write us, we are located at:

**ThinklogicalTM Inc.
100 Washington Street
Milford, CT 06460 USA**

Appendix A: StudioPRO ExtenderTM Models

All models listed are available from ThinklogicalTM:

Part Number	Item Name
VEL-SP0MDL-LCRX	STUDIOPRO EXTENDER, DUAL LINK, 2.0, MULTIMODE, RX, LC
VEL-SP0MDL-LCTX	STUDIOPRO EXTENDER, DUAL LINK, 2.0, MULTIMODE, TX, LC
VEL-SP0MDL-SCRX	STUDIOPRO EXTENDER, DUAL LINK, 2.0, MULTIMODE, RX, SC
VEL-SP0MDL-SCTX	STUDIOPRO EXTENDER, DUAL LINK, 2.0, MULTIMODE, TX, SC
VEL-SP0MDL-STRX	STUDIOPRO EXTENDER, DUAL LINK, 2.0, MULTIMODE, RX, ST
VEL-SP0MDL-STTX	STUDIOPRO EXTENDER, DUAL LINK, 2.0, MULTIMODE, TX, ST
VEL-SP0MSL-LCRX	STUDIOPRO EXTENDER, SINGLE LINK, 2.0, MULTIMODE, RX, LC
VEL-SP0MSL-LCTX	STUDIOPRO EXTENDER, SINGLE LINK, 2.0, MULTIMODE, TX, LC
VEL-SP0MSL-SCRX	STUDIOPRO EXTENDER, SINGLE LINK, 2.0, MULTIMODE, RX, SC
VEL-SP0MSL-SCTX	STUDIOPRO EXTENDER, SINGLE LINK, 2.0, MULTIMODE, TX, SC
VEL-SP0MSL-STRX	STUDIOPRO EXTENDER, SINGLE LINK, 2.0, MULTIMODE, RX, ST
VEL-SP0MSL-STTX	STUDIOPRO EXTENDER, SINGLE LINK, 2.0, MULTIMODE, TX, ST
VEL-SP0SDL-LCRX	STUDIOPRO EXTENDER, DUAL LINK, 2.0, SINGLEMODE, RX, LC/UPC
VEL-SP0SDL-LCTX	STUDIOPRO EXTENDER, DUAL LINK, 2.0, SINGLEMODE, TX, LC/UPC
VEL-SP0SDL-SCRX	STUDIOPRO EXTENDER, DUAL LINK, 2.0, SINGLEMODE, RX, SC/APC
VEL-SP0SDL-SCTX	STUDIOPRO EXTENDER, DUAL LINK, 2.0, SINGLEMODE, TX, SC/APC
VEL-SP0SSL-SCRX	STUDIOPRO EXTENDER, SINGLE LINK, 2.0, SINGLEMODE, RX, SC/APC
VEL-SP0SSL-SCTX	STUDIOPRO EXTENDER, SINGLE LINK, 2.0, SINGLEMODE, TX, SC/APC

Appendix B: SPE Enclosure Dimensions

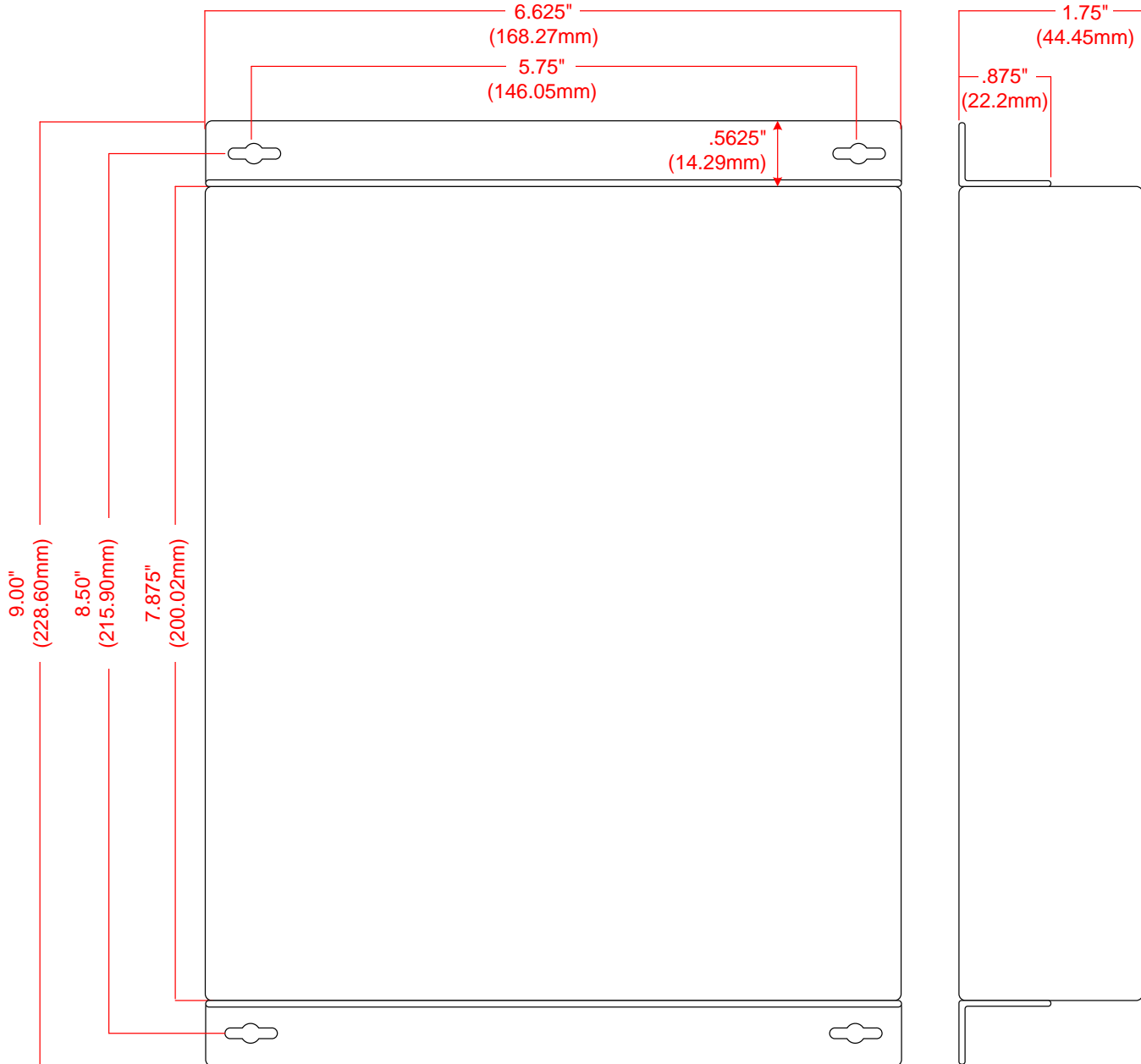

FIGURE 10: *SPE Chassis Dimensions*

NOTE: Drawing is not to scale.

Appendix C: SPE Quick Start Guides

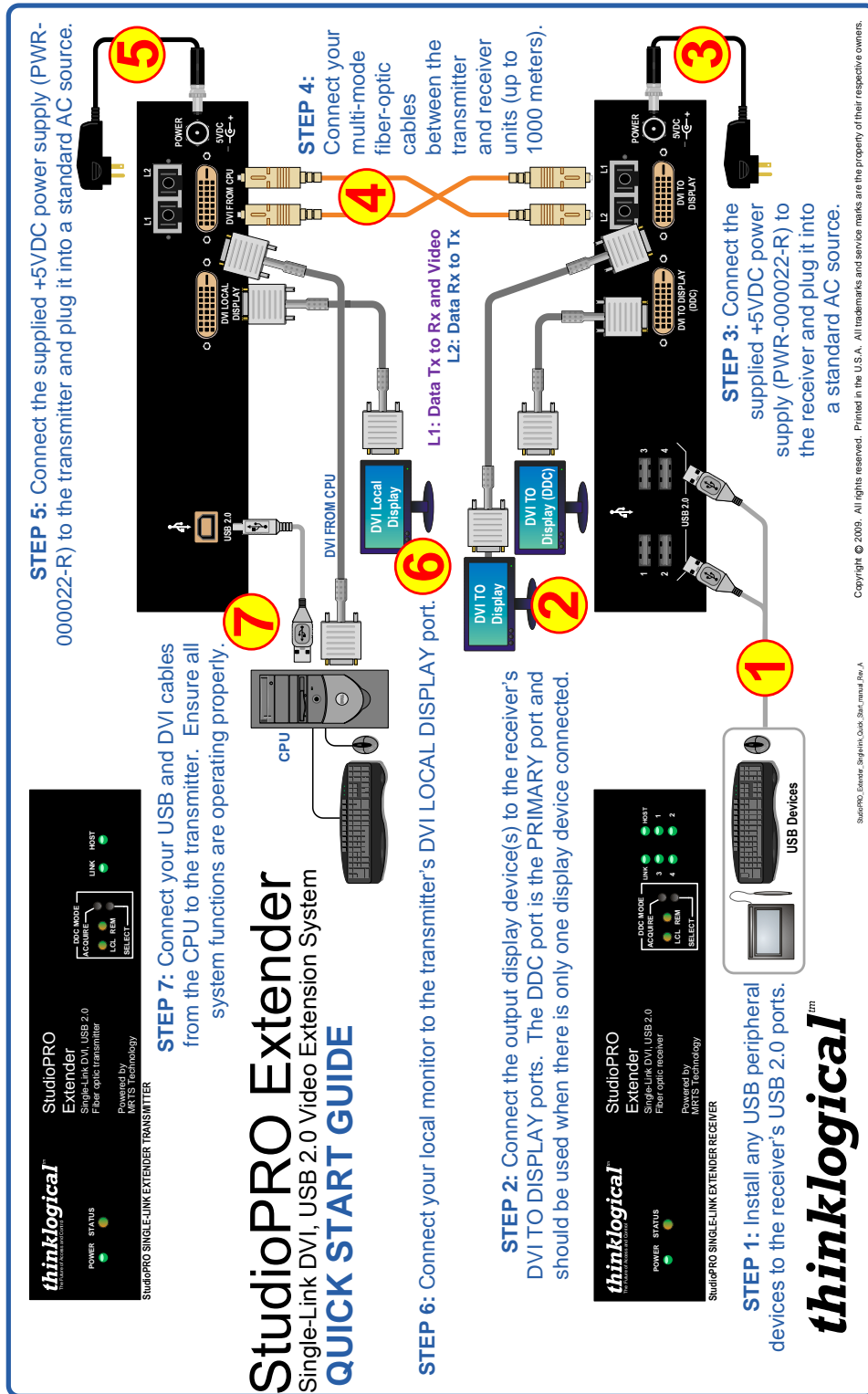

FIGURE 11: StudioPRO Extender Single-Link DVI, USB 2.0 Quick Start Guide

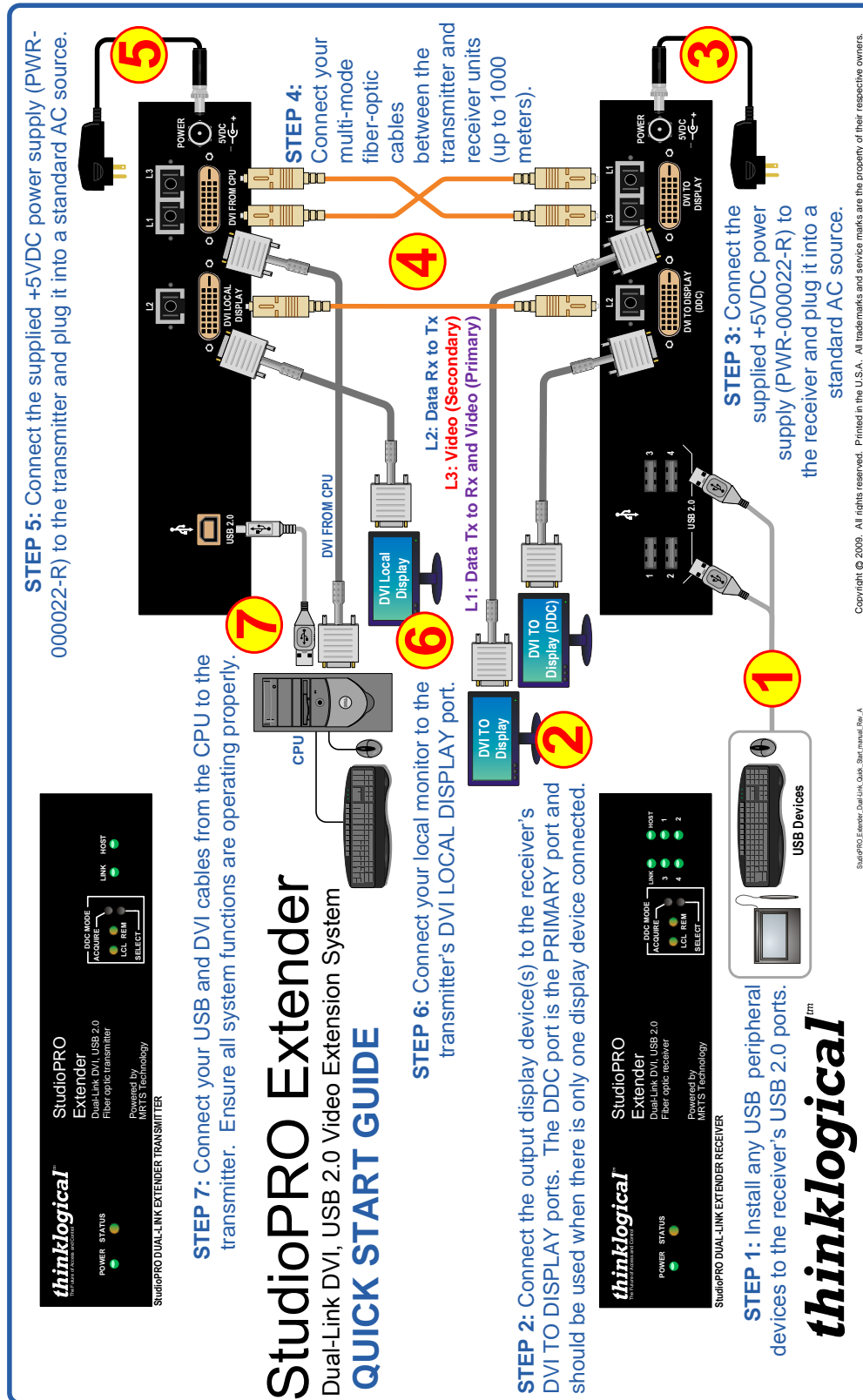
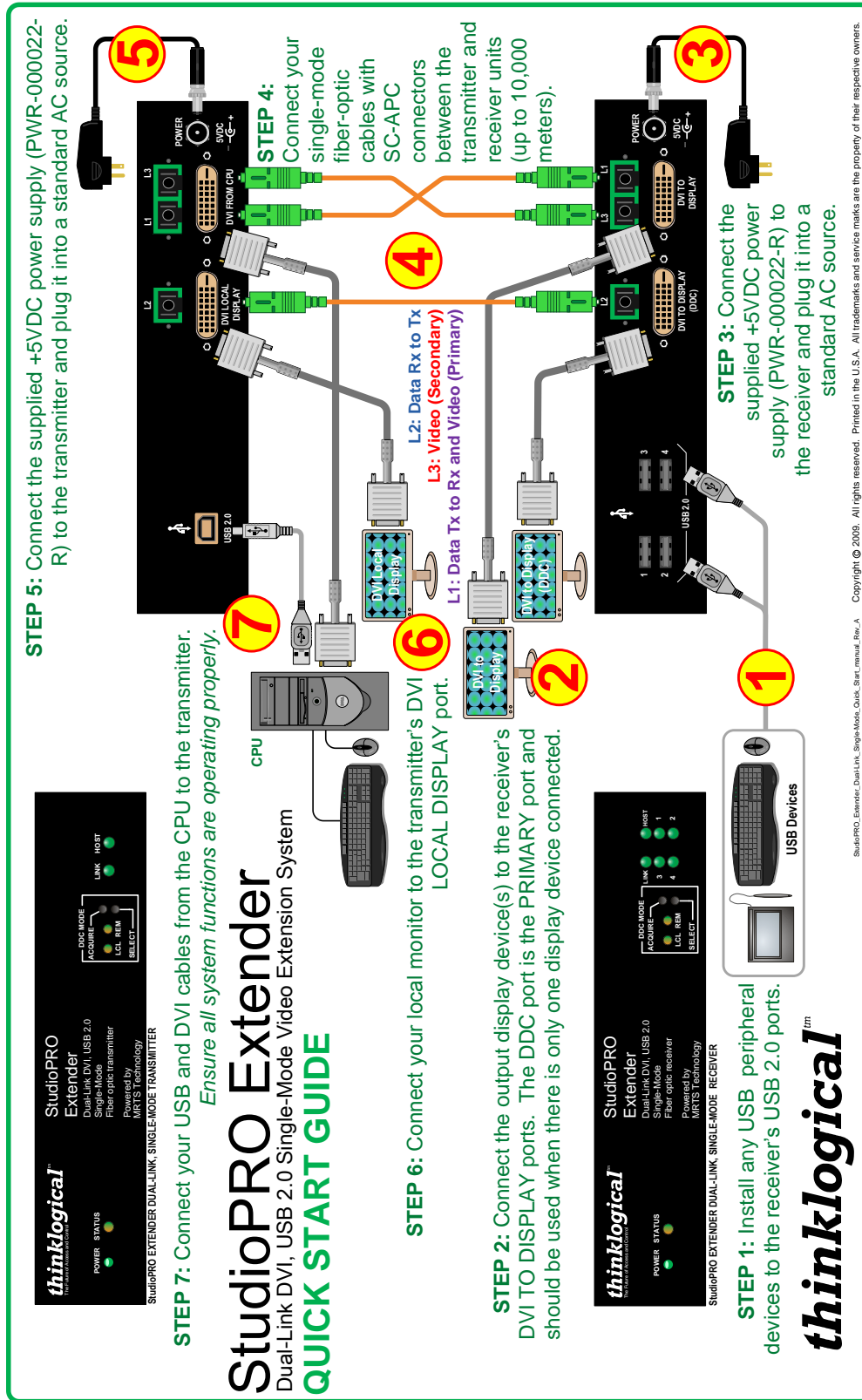

FIGURE 12: StudioPRO Extender Dual-Link DVI, USB 2.0 Quick Start Guide



StudioPRO_Extender_DualLink_SingleMode_Quick_Start_manual_Rev_A Copyright © 2009. All rights reserved. Printed in the U.S.A. All trademarks and service marks are the property of their respective owners.

FIGURE 13: StudioPRO Extender Single-Link DVI, USB 2.0 Single-Mode Video Quick Start Guide

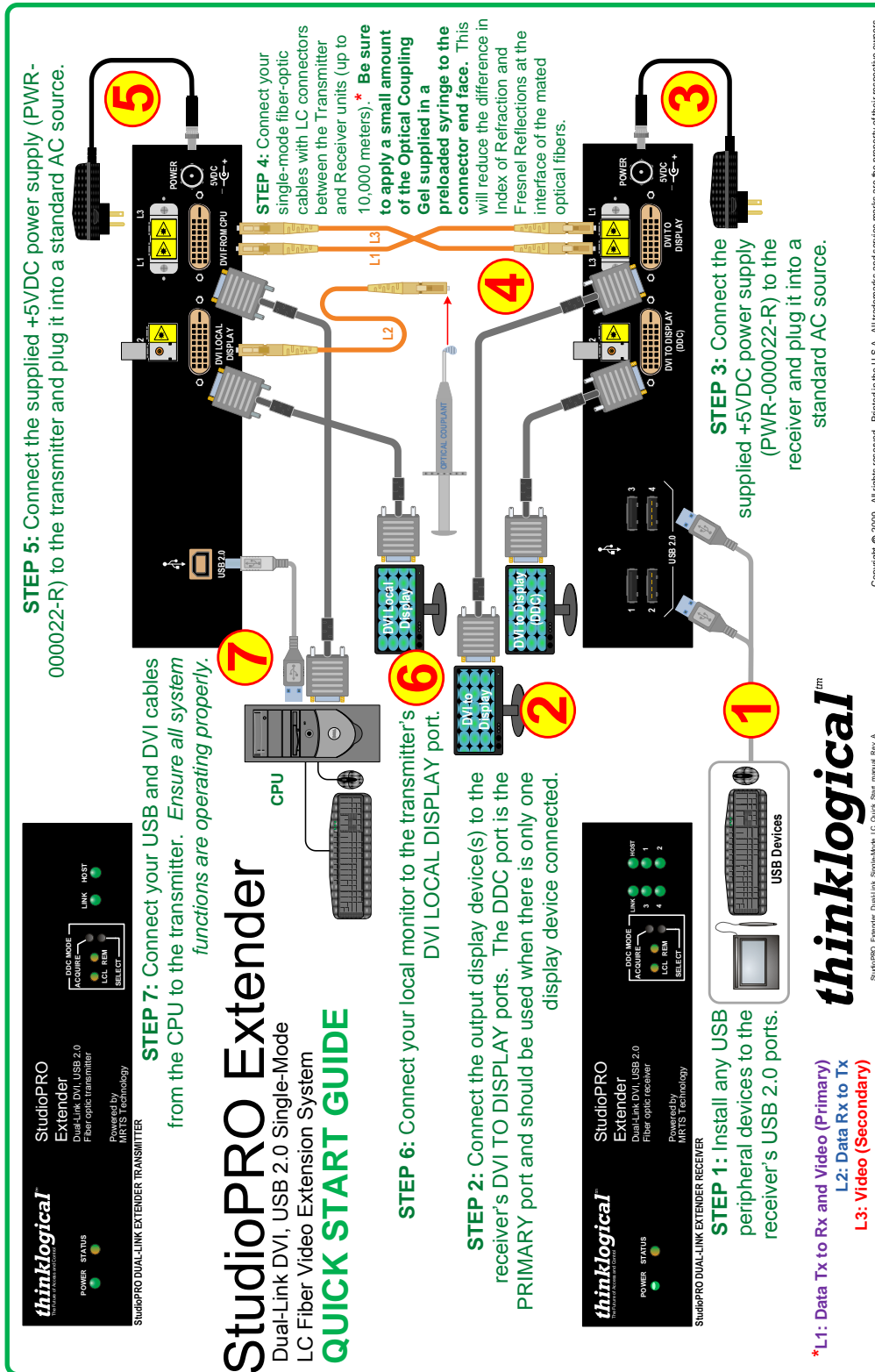

FIGURE 14: StudioPRO Extender Single-Link DVI, USB 2.0 Single-Mode LC Fiber Video Quick Start Guide