

# QUICK-START GUIDE

As used with the Velocityrgb-9 and the Velocitykvm-24  
Fiber Extension Systems

# router VX320 KVM Matrix Switch

Powered by  
MRTS Technology

The VX320 Router Critical Hardware Alarms: (Located at the top, left rear of the unit.)

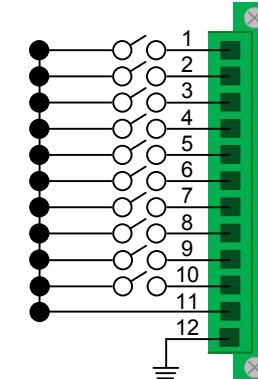

- POWER SUPPLY 1 (LEFT): Fan failure, temperature spikes, DC voltage and/or current out of range, AC power input interruption or module removed
- POWER SUPPLY 2: Fan failure, temperature spikes, DC voltage and/or current out of range, AC power input interruption or module removed
- POWER SUPPLY 3: Fan failure, temperature spikes, DC voltage and/or current out of range, AC power input interruption or module removed
- POWER SUPPLY 4 (RIGHT): Fan failure, temperature spikes, DC voltage and/or current out of range, AC power input interruption or module removed
- FANS: Individual fan monitoring
- TEMPERATURE WARNING: Chassis over temperature, multiple sensors
- TEMPERATURE SHUTDOWN: Chassis over temperature causing shutdown
- CPU: Card failure (Only with a redundant card)
- INPUT/OUTPUT CARDS: SFP+ failure, laser output fault
- ANY OF THE ABOVE
- COMMON
- GROUND

## Dual Head DVI & KVM Source

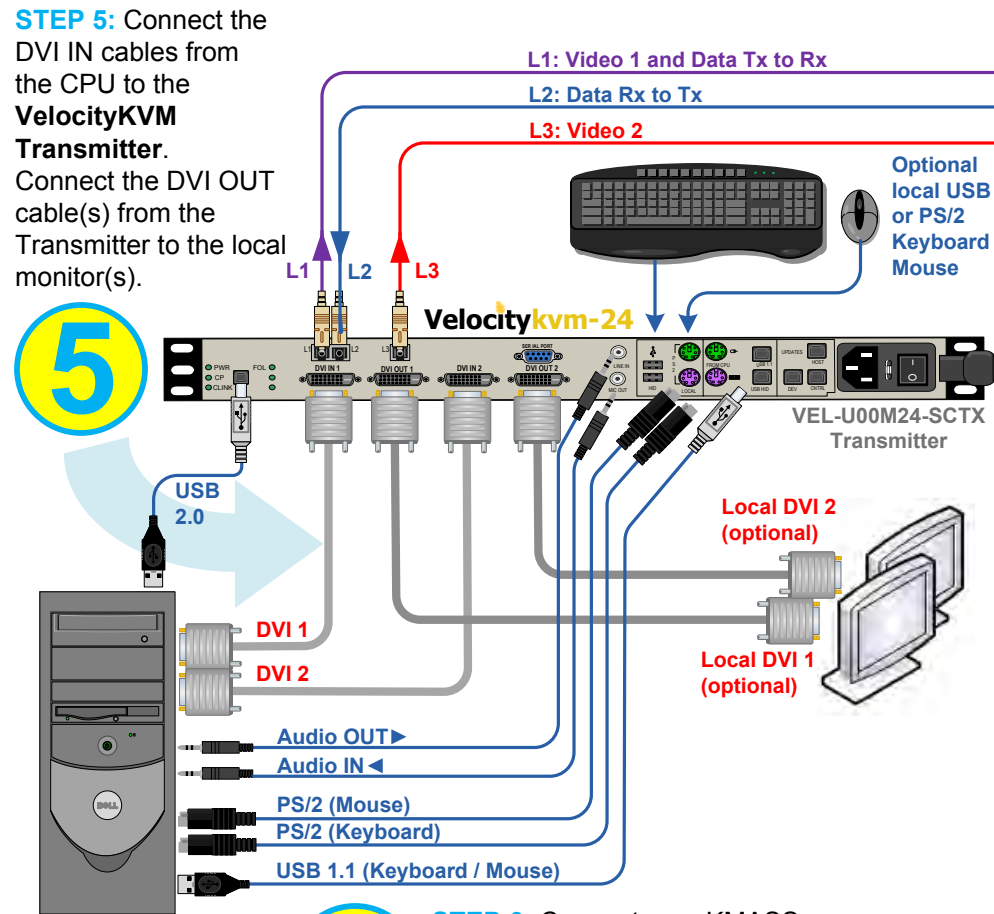

**STEP 5:** Connect the DVI IN cables from the CPU to the VelocityKVM Transmitter. Connect the DVI OUT cable(s) from the Transmitter to the local monitor(s).

**STEP 6:** Connect your KMASS devices from the Source CPU to the appropriate VelocityKVM Transmitter ports.

## Single Head RGB Source

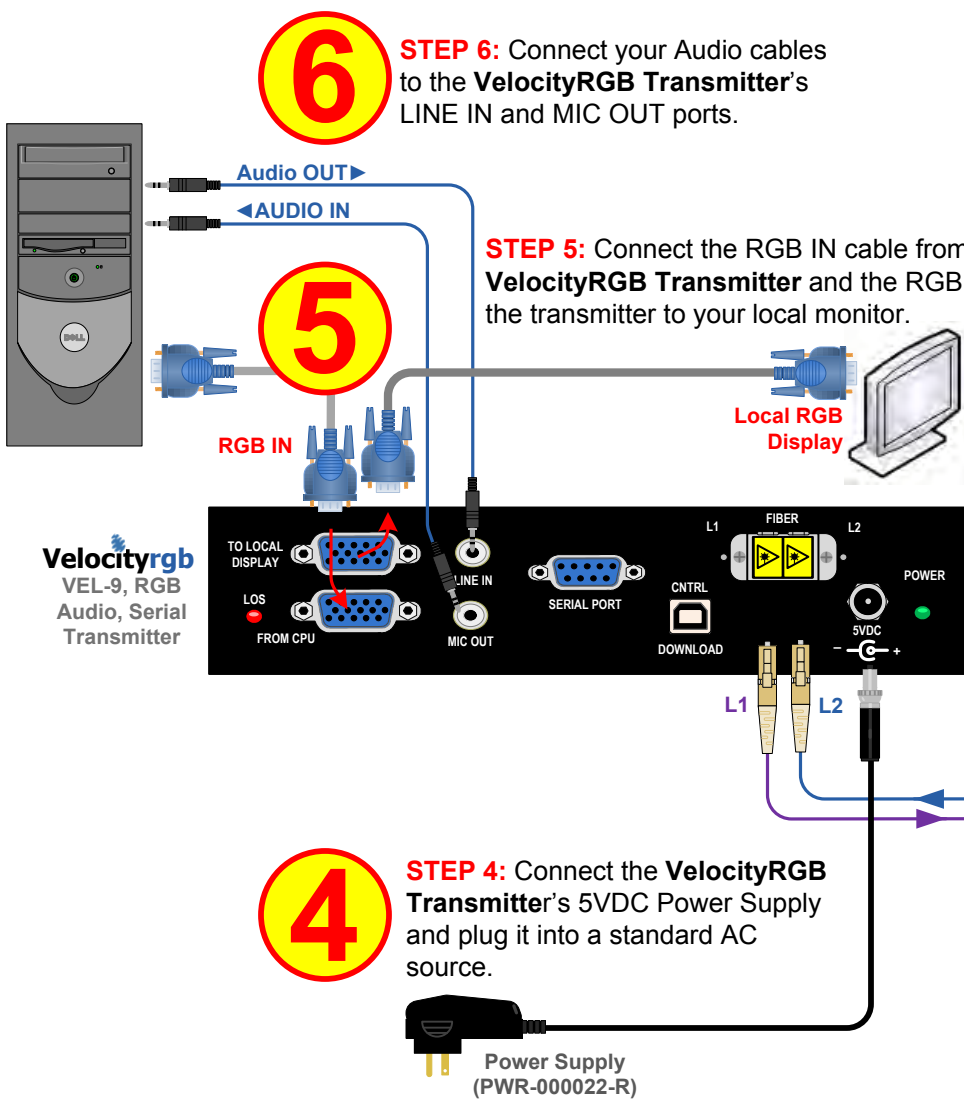

**STEP 6:** Connect your Audio cables to the VelocityRGB Transmitter's LINE IN and MIC OUT ports.

**STEP 5:** Connect the RGB IN cable from the CPU to the VelocityRGB Transmitter and the RGB OUT cable from the transmitter to your local monitor.

**STEP 4:** Connect the VelocityRGB Transmitter's 5VDC Power Supply and plug it into a standard AC source.

**STEP 3:** Connect your Velocity Transmitter to the VX320 using multi-mode fiber-optic cables (up to 1000 meters). Connect L1 to any VX320 Upper Card Cage Receive Port. Connect L2 to any Lower Card Cage Transmit Port. (See the Digital Crosspoint Switch detail diagram, right.)

**STEP 8:** Connect the four supplied AC Power Cords (PWR-0000056-R) to the receptacles located on the VX320's power supplies. Plug each of them into a standard AC source. Verify that all system functions are operating properly.

**8**

- \* Power supplies, Left to Right:
- 1 Upper Card Cage Primary
- 2 Upper Card Cage Back-up
- 3 Lower Card Cage Primary
- 4 Lower Card Cage Back-up

**STEP 4:** Ensure the VelocityKVM Transmitter's ON/OFF switch is in the OFF (0) position. Connect the AC Power Cord and plug it into a standard AC source. Turn the switch ON.

**4**

**STEP 3:** Connect your Velocity Transmitter to the VX320 using multi-mode fiber-optic cables (up to 1000 meters). Connect L1 and L3 to any VX320 Upper Card Cage Receive Ports. Connect L2 to any Lower Card Cage Transmit Port. (See the Digital Crosspoint Switch detail diagram, below.)

**3**

VX320 Router KVM Matrix Switch Chassis, 24 Rack Units, 1600 Watts

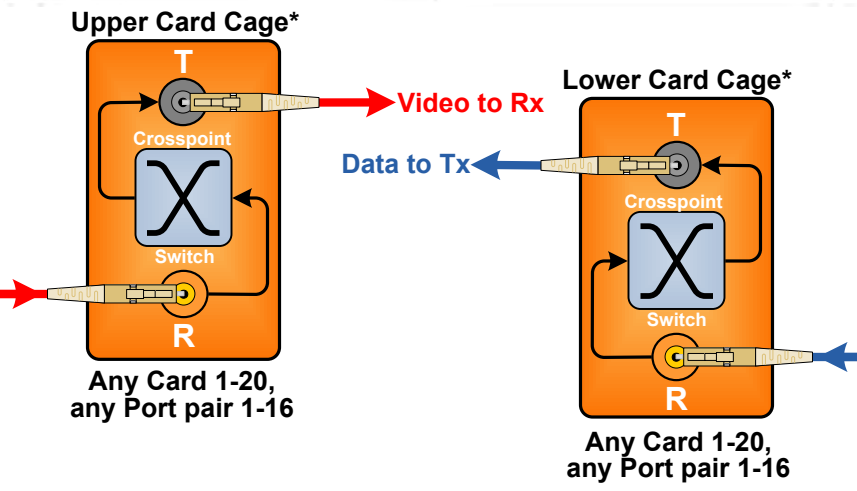
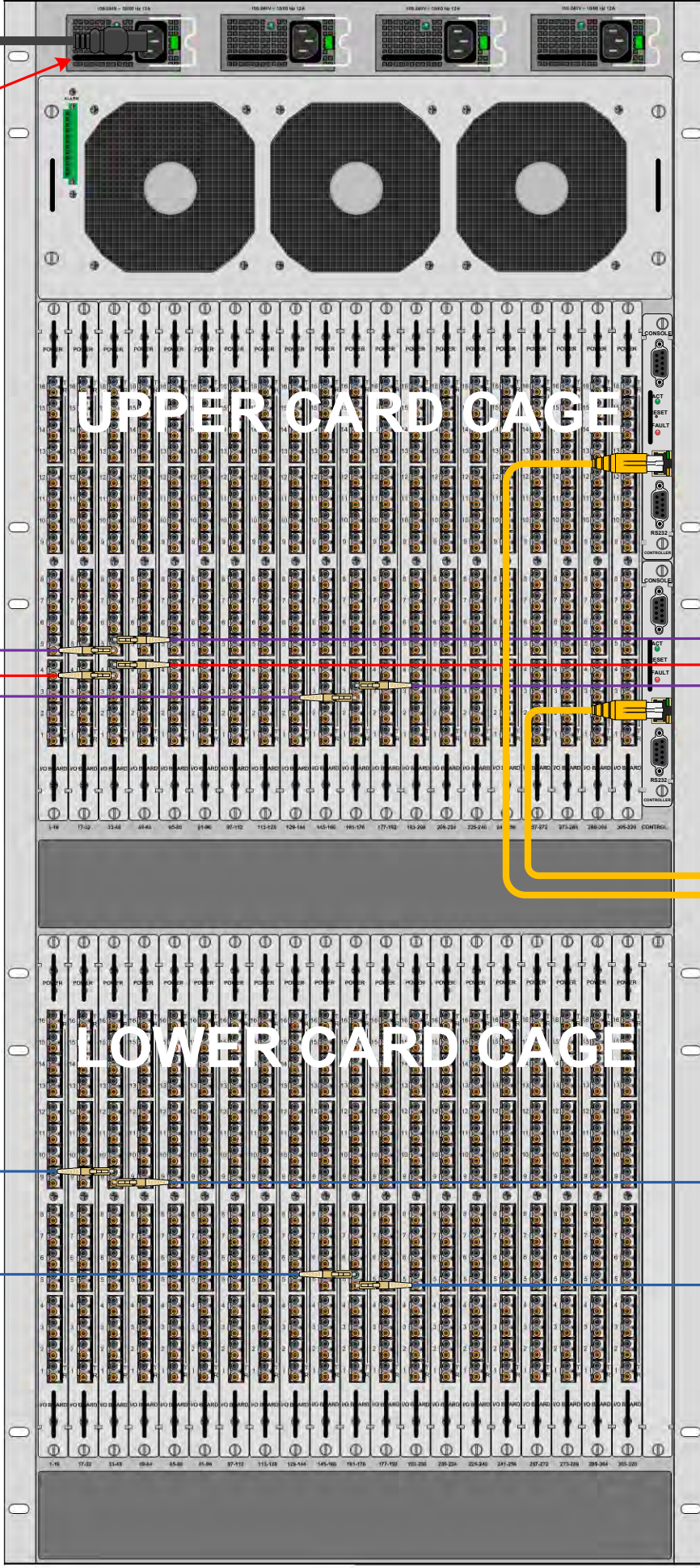

\*Both the Upper and Lower Card Cages are designed to handle either Video or Data signals.

Thinklogical's™ VX320 KVM Matrix Switch features redundant Power Supplies and Fail-Over Controller Modules for uninterrupted performance, even during system reconfiguration, updates or debug. The VX320 remains fully functional with only one of the two Upper or Lower Card Cage Power Supplies installed or with one Controller activated.

**NOTE:** When using a single Controller, the upper module (Primary) must be installed.

- ### CONTENTS
- Upon receiving your Thinklogical™ VX320 KVM Matrix Switch you should find the following items:
- VX320 Chassis & Cards
  - LC Duplex Bulkhead with Flange
  - 15' CAT5 Cable (1)
  - AC Power Cord (4)
  - Product Manual CD

## Dual Head DVI & KVM Destinations

**STEP 1:** Connect your Velocity Receiver to the VX320 using multi-mode fiber-optic cables (up to 1000 meters). Connect cables L1\* and L3 to any Transmit Ports on any cards of the Upper Card Cage. Connect cable L2 to any Receive Port on any card of the Lower Card Cage. (See the Digital Crosspoint Switch detail diagram, below left.)

**STEP 2:** Ensure that the Receiver's ON/OFF switch is in the OFF (0) position. Depending on your configuration, connect your desktop devices (monitors, keyboard, mouse, etc.) to the VelocityKVM Receiver using standard cables as shown in the example below. Turn all the devices ON. Insert the AC power cord into the Receiver and plug it into a standard AC source. Turn the unit ON.

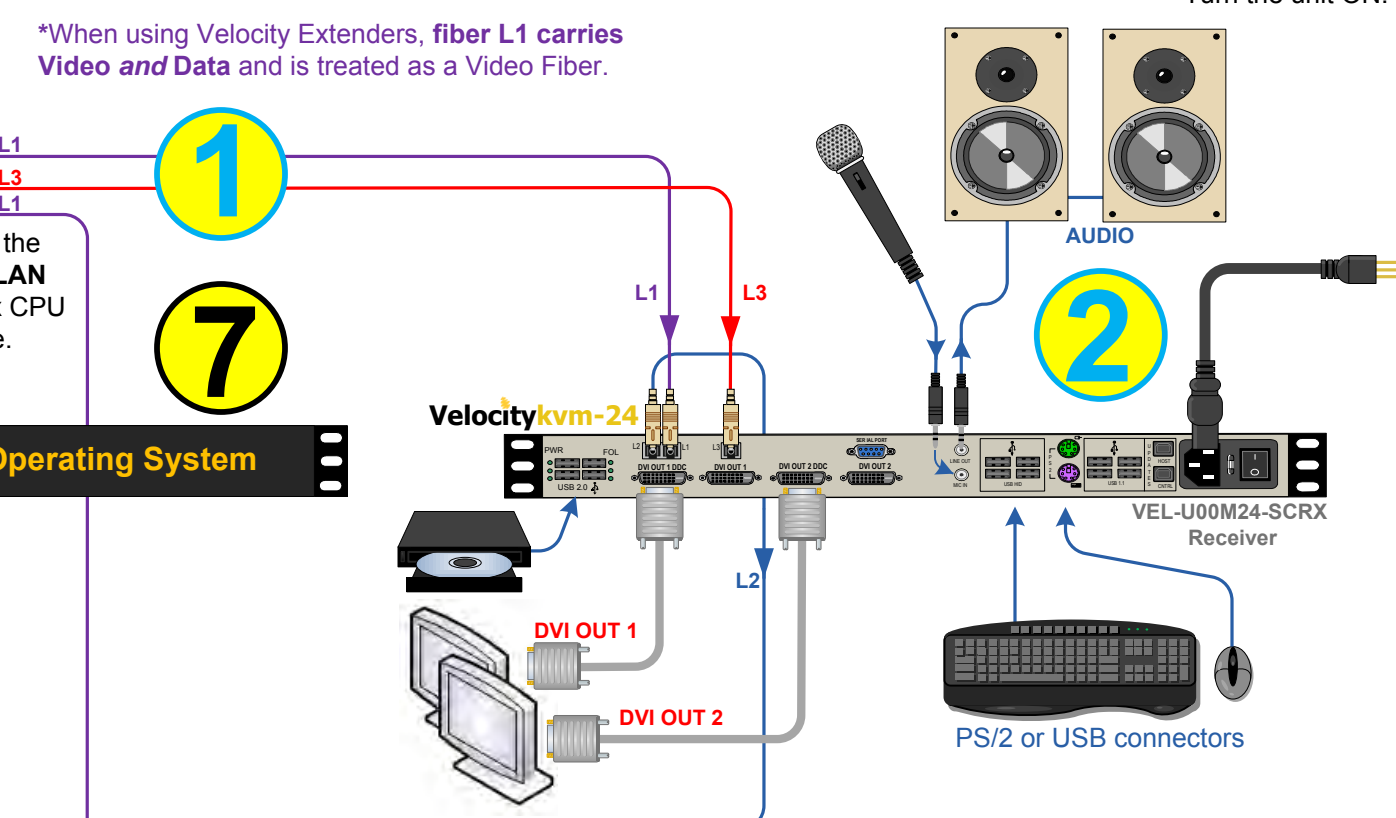

\*When using Velocity Extenders, fiber L1 carries Video and Data and is treated as a Video Fiber.

**STEP 7:** Connect the Controller Card LAN Port to your Linux CPU with a CAT5 cable. (IP address: 192.168.13.15)

**Linux Operating System**

**STEP 1:** Connect your Velocity Receiver to the VX320 using multi-mode fiber-optic cables (up to 1000 meters). Connect L1\* to any Transmit Port on any card of the Upper Card Cage and L2 to any Receive Port on any card of the Lower Card Cage. (See the Digital Crosspoint Switch detail diagram, left.)

## Monitor, Projector and Audio Destinations

**STEP 1:** Connect your Velocity Receiver to the VX320 using multi-mode fiber-optic cables (up to 1000 meters). Connect L1\* to any Transmit Port on any card of the Upper Card Cage and L2 to any Receive Port on any card of the Lower Card Cage. (See the Digital Crosspoint Switch detail diagram, left.)

**STEP 2:** Connect your output devices (monitors, audio speakers, projector, etc.) to the VelocityRGB Receiver. Install the Receiver's 5VDC power supply and plug it into a standard AC source.

