

QUICK-START GUIDE

As used with the Velocitydvi-3 and the Velocitykvm-4
Fiber Extension Systems

router VX320 KVM Matrix Switch

The VX320 Router Critical Hardware Alarms: (Located at the top, left rear of the unit.)

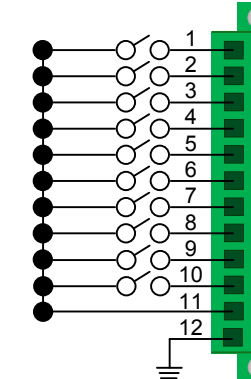

POWER SUPPLY 1 (LEFT): Fan failure, temperature spikes, DC voltage and/or current out of range, AC power input interruption or module removed
POWER SUPPLY 2: Fan failure, temperature spikes, DC voltage and/or current out of range, AC power input interruption or module removed
POWER SUPPLY 3: Fan failure, temperature spikes, DC voltage and/or current out of range, AC power input interruption or module removed
POWER SUPPLY 4 (RIGHT): Fan failure, temperature spikes, DC voltage and/or current out of range, AC power input interruption or module removed
FANS: Individual fan monitoring
TEMPERATURE WARNING: Chassis over temperature, multiple sensors
TEMPERATURE SHUTDOWN: Chassis over temperature causing shutdown
CPU: Card failure (Only with a redundant card)
INPUT/OUTPUT CARDS: SFP+ failure, laser output fault
ANY OF THE ABOVE COMMON GROUND

Powered by
MRTS Technology

CONTENTS
Upon receiving your Thinklogical™ VX320 KVM Matrix Switch you should find the following items:

- VX320 Chassis & Cards
- LC Duplex Bulkhead with Flange
- 15' CAT5 Cable (1)
- AC Power Cord (4)
- Product Manual CD

Thinklogical's™ VX320 KVM Matrix Switch features redundant Power Supplies and Fail-Over Controller Modules for uninterrupted performance, even during system reconfiguration, updates or debug. The VX320 remains fully functional with only one of the two Upper or Lower Card Cage Power Supplies installed or with one Controller activated.

NOTE: When using a single Controller, the upper module (Primary) must be installed.

STEP 8: Connect the four supplied AC Power Cords (PWR-000056-R) to the receptacles located on the VX320's power supplies.* Plug each of them into a standard AC source. Verify that all system functions are operating properly.

Single Head DVI & KVM Source

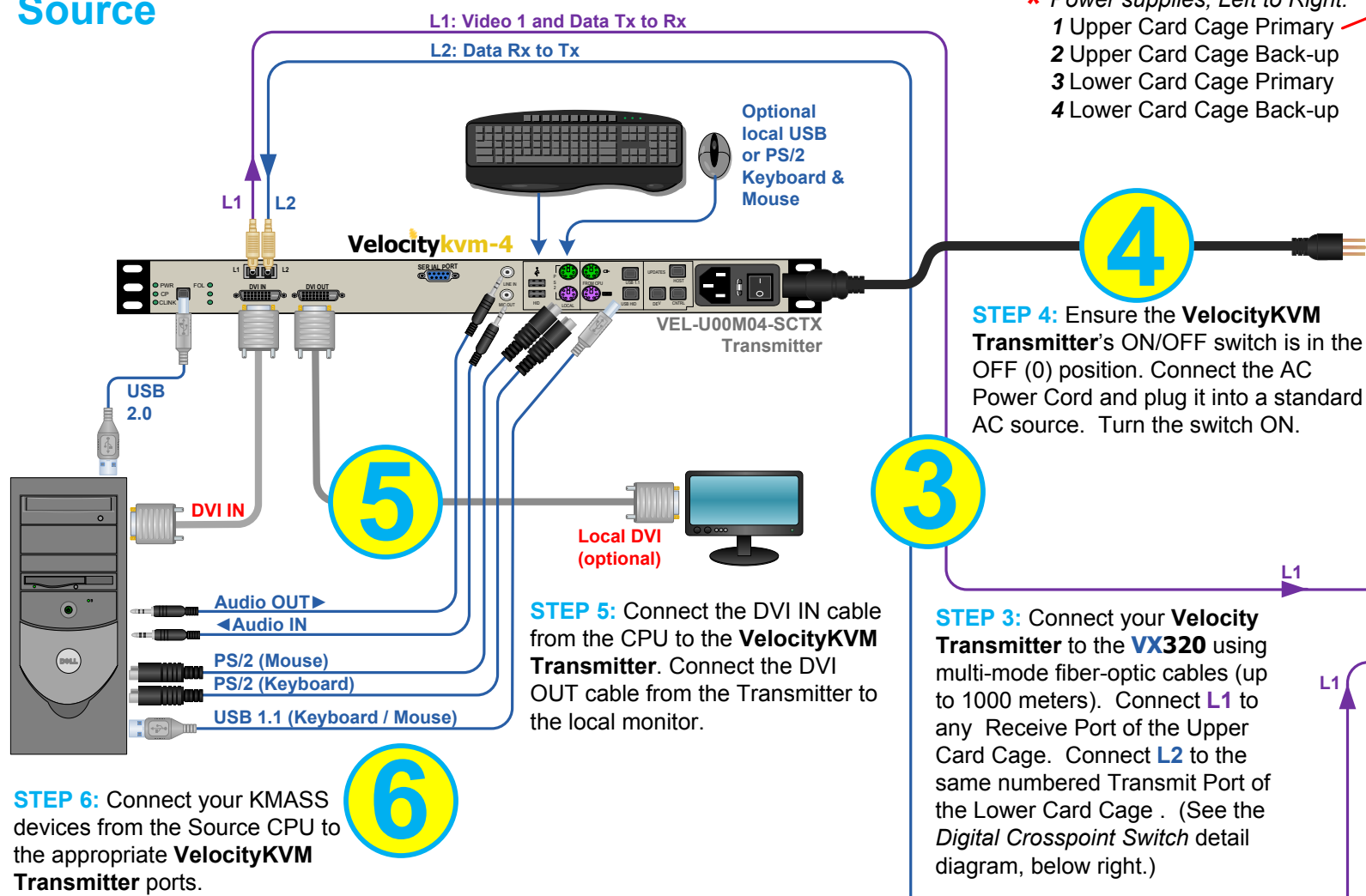

Single Head DVI Source

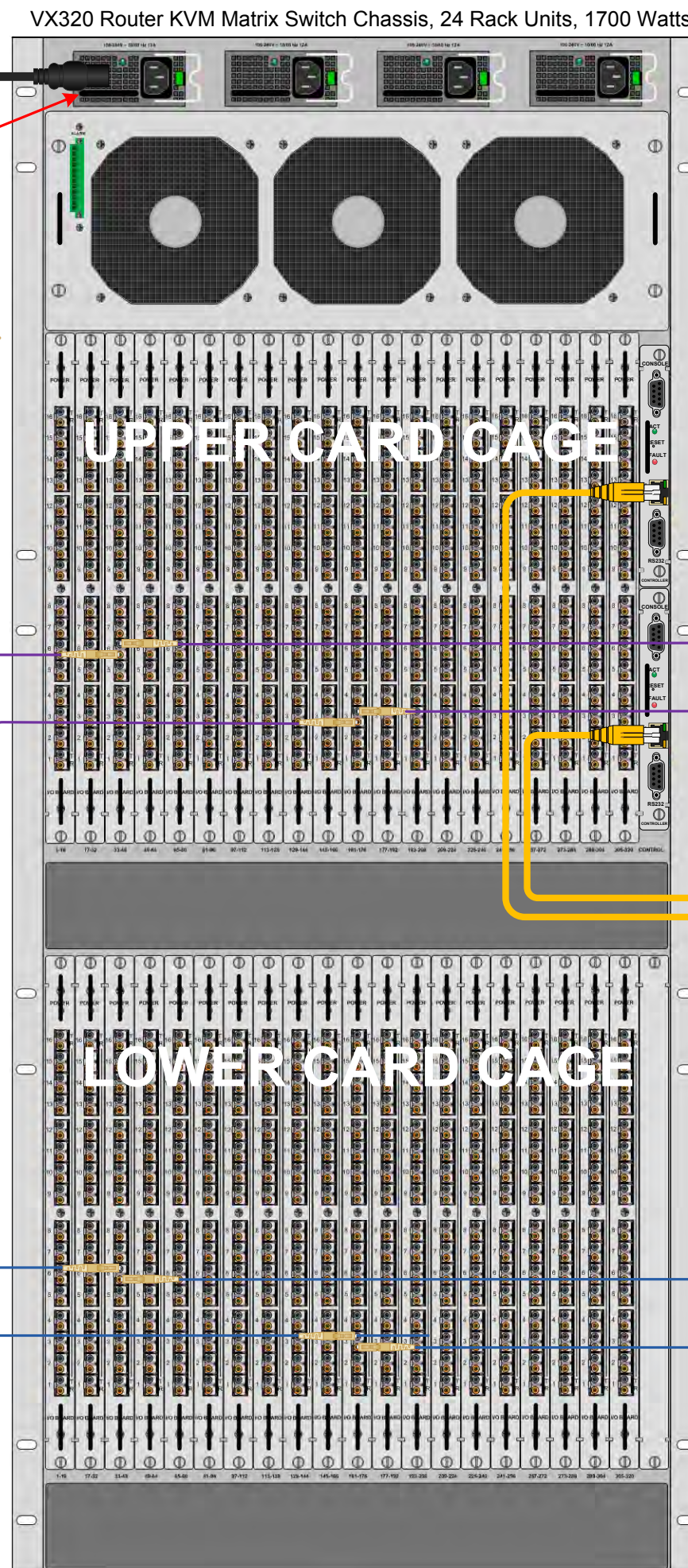
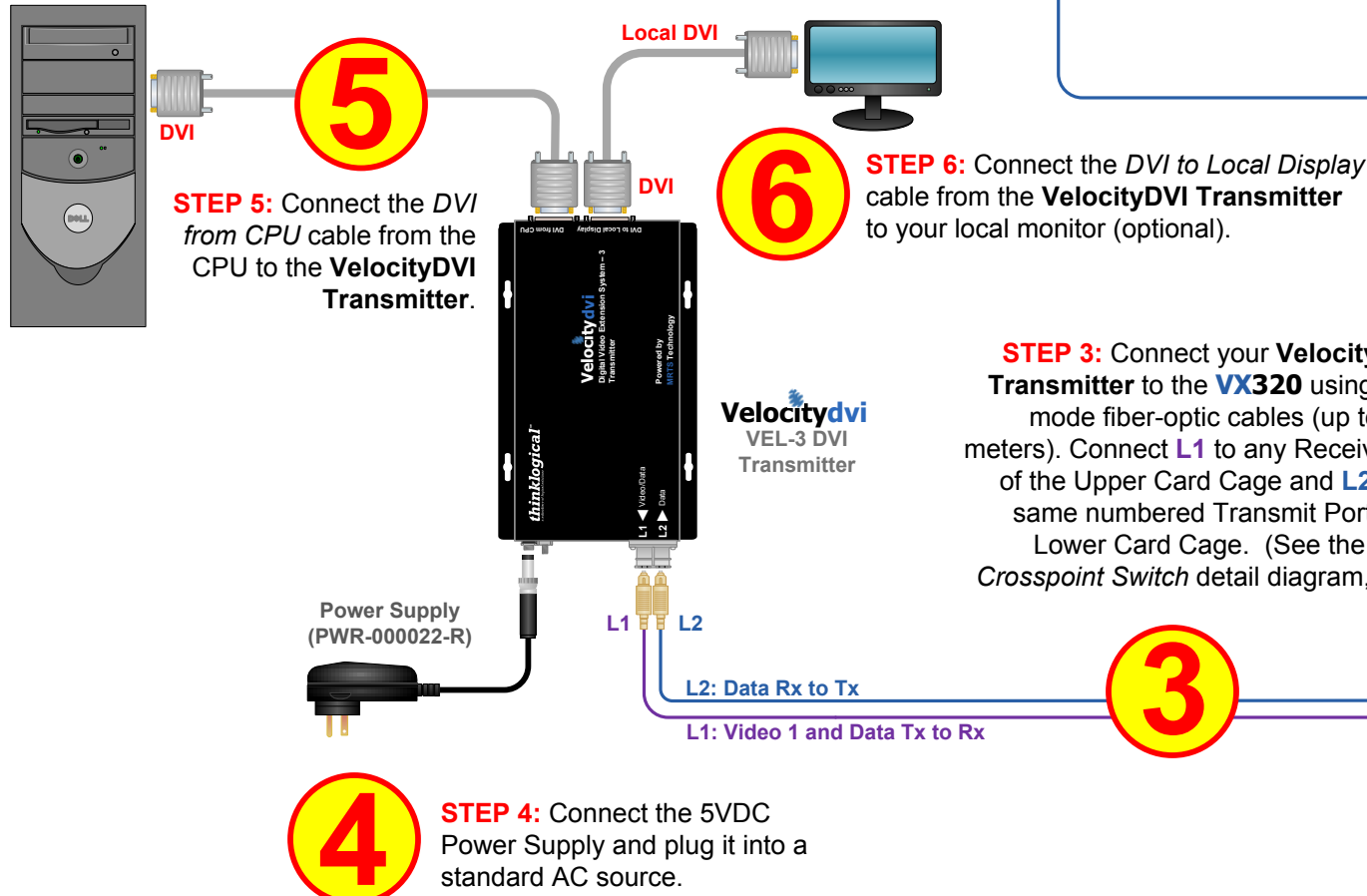

Single Head DVI & KVM Destination

STEP 1: Connect your Velocity Receiver to the VX320 using multi-mode fiber-optic cables (up to 1000 meters). Connect cable L1* to any Transmit Port on any card of the Upper Card Cage. Connect cable L2 to the same numbered Receive Port of the Lower Card Cage. (See the Digital Crosspoint Switch detail diagram, below left.)

*When using Velocity Extenders, fiber L1 carries Video and Data and is treated as a Video Fiber.

STEP 2: Ensure that the Receiver's ON/OFF switch is in the OFF (0) position. Depending on your configuration, connect your desktop devices (monitors, keyboard, mouse, etc.) to the VelocityKVM Receiver using standard cables as shown in the example below. Turn all the devices ON. Insert the AC power cord into the Receiver and plug it into a standard AC source. Turn the unit ON.

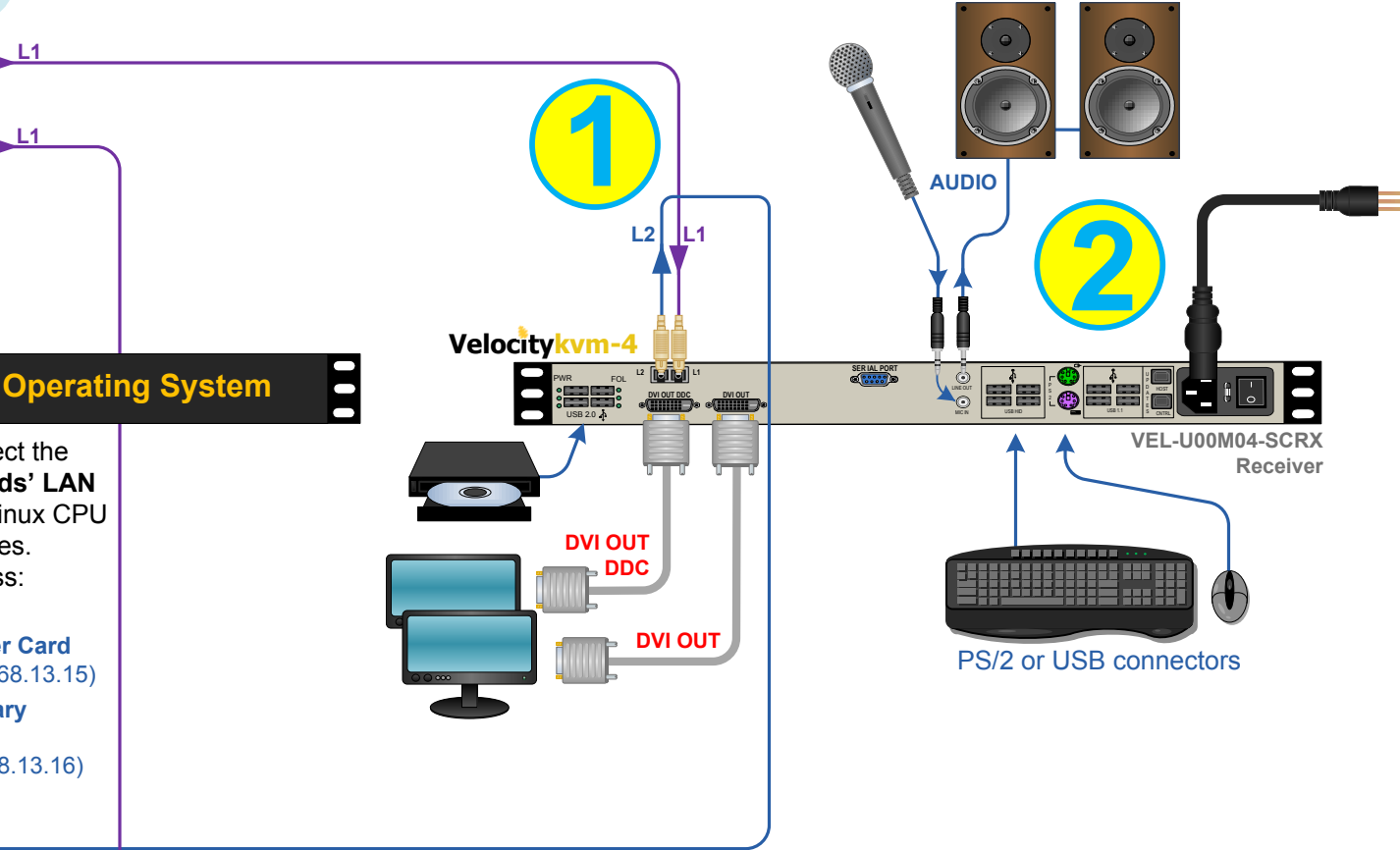

Single Head DVI Destination

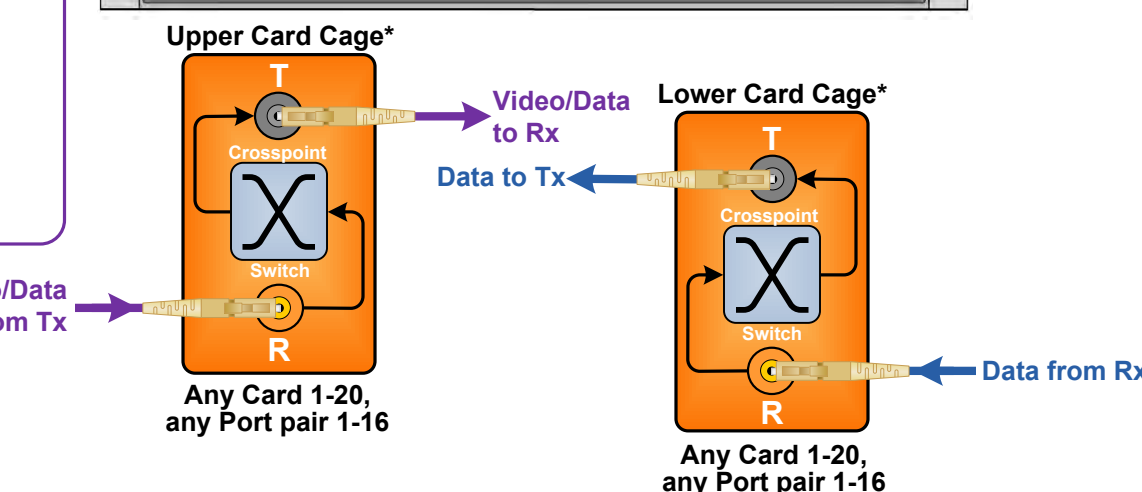
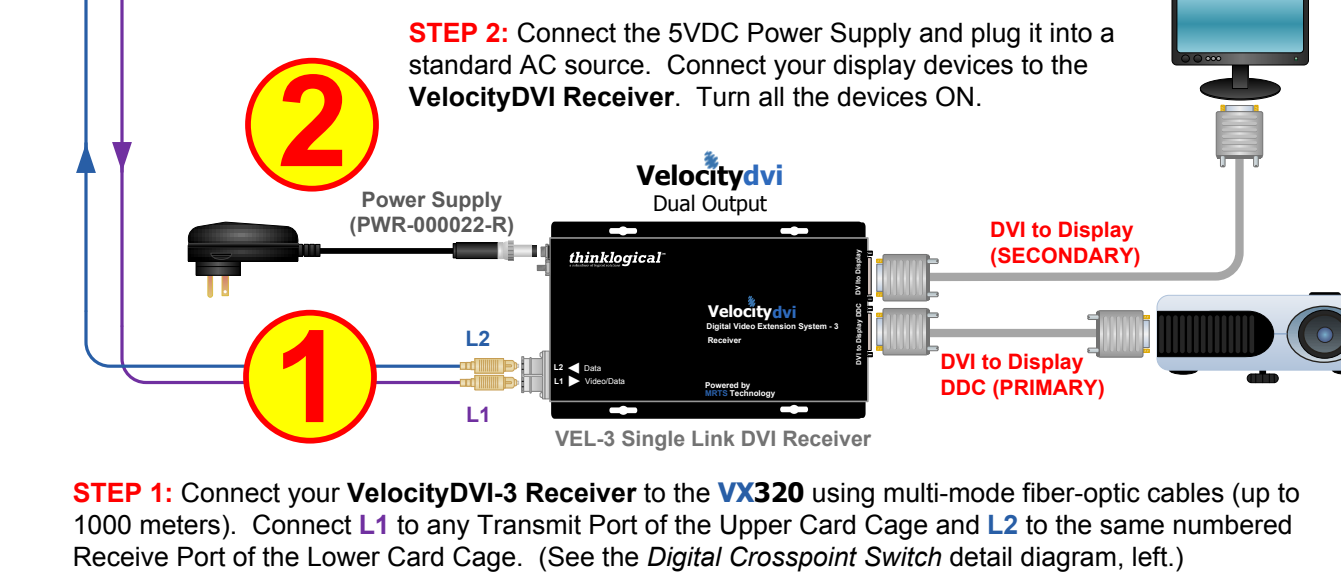

*Both the Upper and Lower Card Cages are designed to handle either Video or Data signals.

thinklogical™

PHONE: 1-800-291-3211
 WEBSITE: www.thinklogical.com
 EMAIL: support@thinklogical.com

Visit us online at www.thinklogical.com for more product information, current updates and the complete line of Thinklogical™ products.