

QUICK-START GUIDE

As used with Thinklogical's™ Velocitykvm-4 and the Velocitykvm-24 Video Extension Systems

router VX40 KVM Matrix Switch

Powered by
MRTS Technology

The VX40 Router Critical Hardware Alarms: (Located at the top, left rear of the unit.)

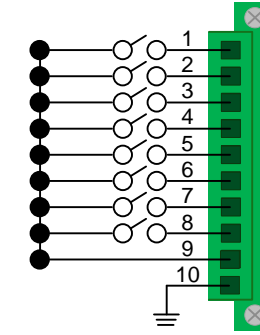

- POWER SUPPLY 1 (LEFT): Fan failure, temperature spikes, DC voltage and/or current out of range, AC power input interruption and module removed
- POWER SUPPLY 2 (RIGHT): Fan failure, temperature spikes, DC voltage and/or current out of range, AC power input interruption and module removed
- FANS: Individual fan monitoring
- TEMPERATURE WARNING: Chassis over temperature, multiple sensors
- TEMPERATURE SHUTDOWN: Chassis over temperature causing shutdown
- CPU: Card failure (Only with a redundant card)
- INPUT/OUTPUT CARDS: SFP+ failure, laser output fault
- ANY OF THE ABOVE
- COMMON GROUND

Single-Head, Single-Link DVI/KVM Source

STEP 5: Connect the DVI IN cable from the CPU to the VelocityKVM Transmitter. Connect the DVI OUT cable from the Transmitter to the local monitor.

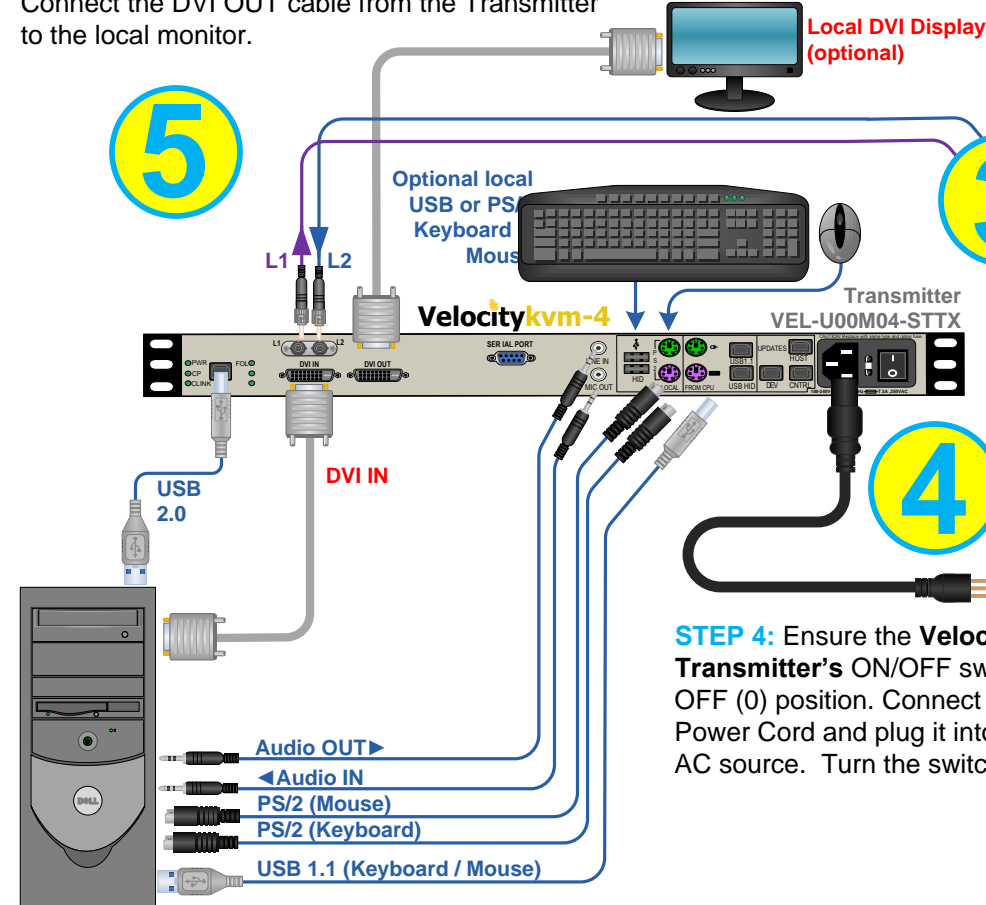

STEP 3: Connect your VelocityDVI Transmitter to the VX40 using multi-mode fiber-optic cables (up to 1000 meters). Connect cable L1 to any Upstream Receive Port and cable L2 to the same numbered Upstream Transmit Port as shown. (See the Digital Crosspoint Switch detail diagram, below.)

STEP 4: Ensure the VelocityKVM Transmitter's ON/OFF switch is in the OFF (0) position. Connect the AC Power Cord and plug it into a standard AC source. Turn the switch ON.

STEP 6: Connect your KMASS devices from the Source CPU to the appropriate VelocityKVM Transmitter ports.

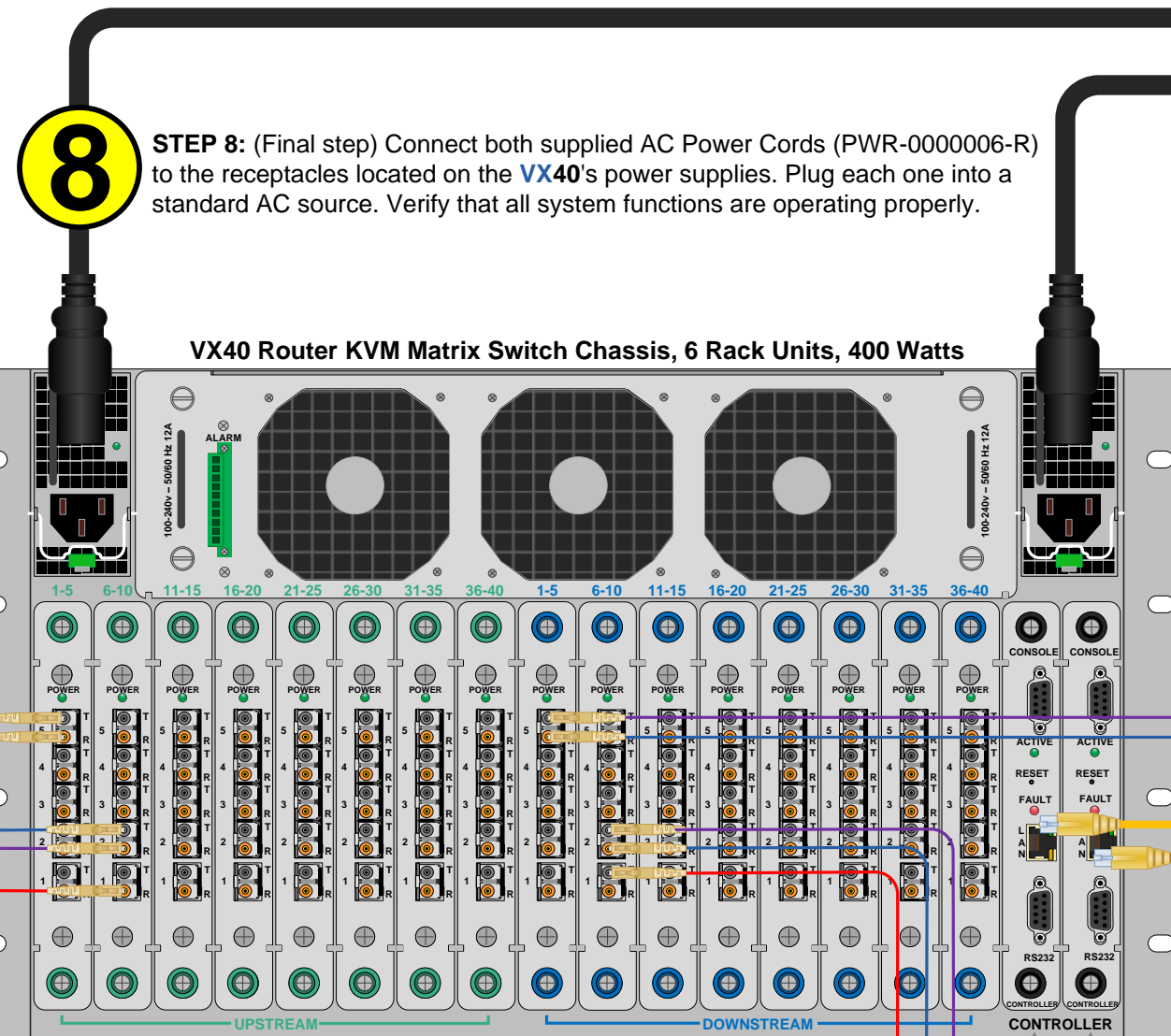

STEP 8: (Final step) Connect both supplied AC Power Cords (PWR-000006-R) to the receptacles located on the VX40's power supplies. Plug each one into a standard AC source. Verify that all system functions are operating properly.

★ Primary Controller Card
Optional Secondary Controller Card

STEP 7: Connect the Controller Card LAN Port to your Controller CPU with a CAT5 cable. (IP address: 192.168.13.15)

Single-Link, DVI 2 Display/KVM Source

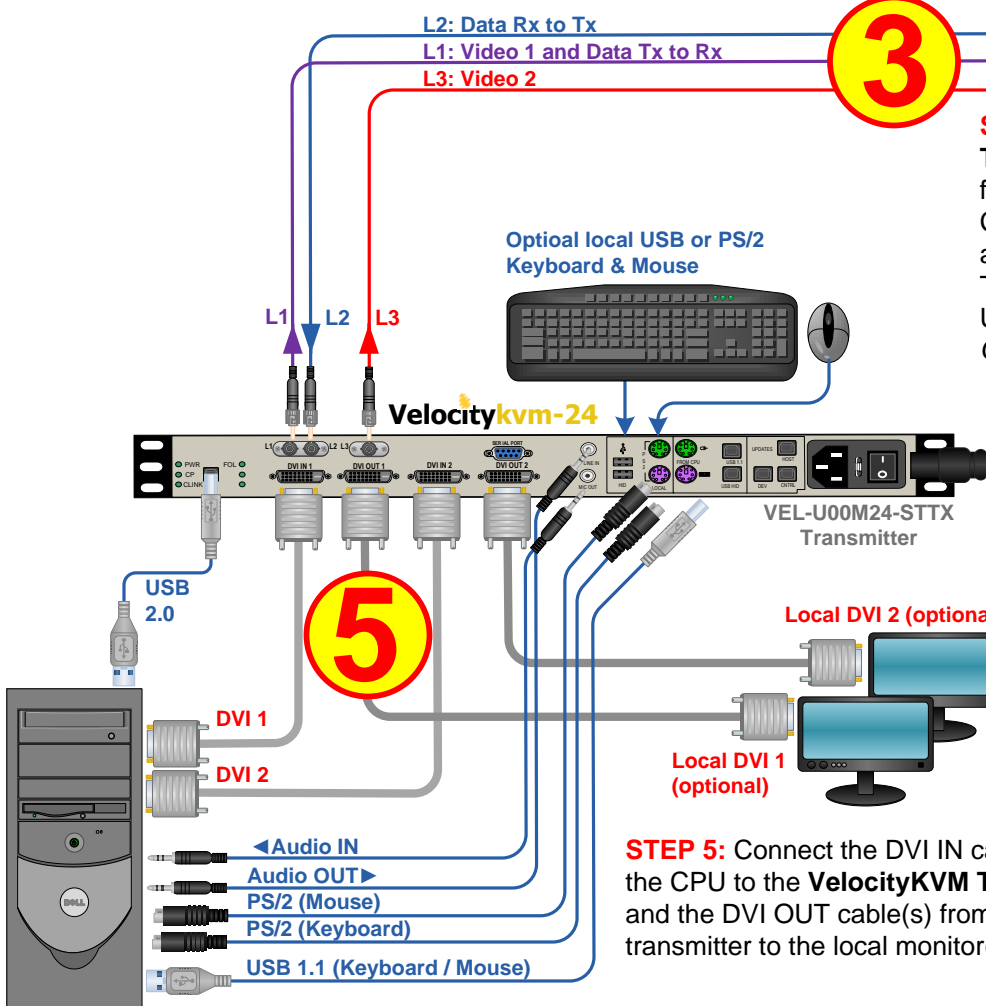

STEP 3: Connect your VelocityKVM Transmitter to the VX40 using multi-mode fiber-optic cables (up to 1000 meters). Connect L1 to any Upstream Receive Port and L2 to the same numbered Upstream Transmit Port. Connect L3 to any other Upstream Receive Port. (See the Digital Crosspoint Switch detail diagram, right.)

STEP 4: Ensure the VelocityKVM Transmitter's ON/OFF switch is in the OFF (0) position. Connect the Power Cord and plug it into a standard AC source. Turn the switch ON (1).

STEP 5: Connect the DVI IN cables from the CPU to the VelocityKVM Transmitter and the DVI OUT cable(s) from the transmitter to the local monitor(s).

STEP 6: Connect your USB, PS/2 and Audio sources to the VelocityKVM Transmitter's inputs.

Network Hub

External Control CPU

Digital Crosspoint Switch

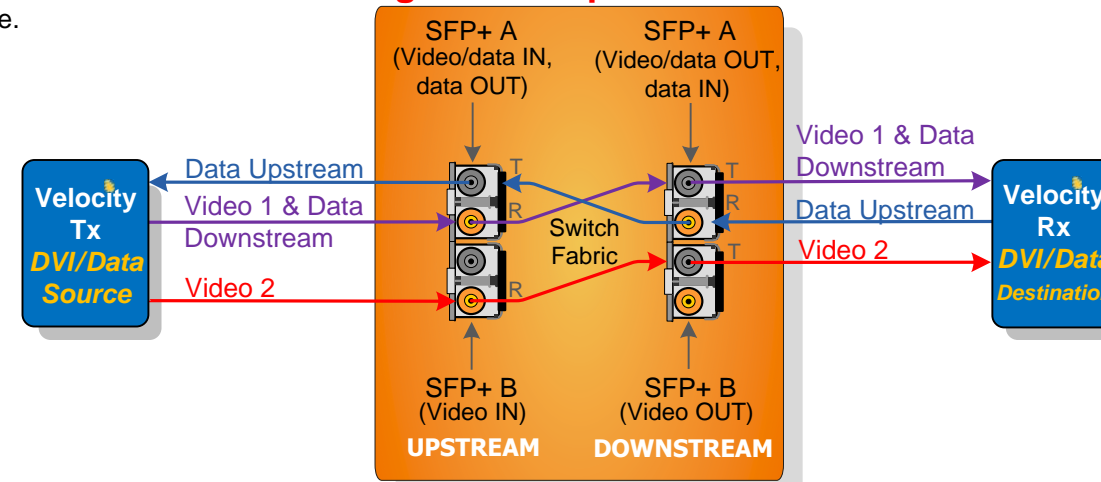

Single-Head, Single-Link DVI/KVM Destinations

STEP 2: Ensure that the VelocityKVM Receiver's ON/OFF switch is in the OFF (0) position. Depending on your configuration, connect your desktop devices (monitors, keyboard, mouse, etc.) to the Receiver using standard cables as shown in the example below. Turn all the devices ON. Insert the AC power cord into the Receiver and plug it into a standard AC source. Turn the unit ON.

STEP 1: Connect your VelocityKVM Receiver to the VX40 using multi-mode fiber-optic cables (up to 1000 meters). Connect L1 to any Downstream Transmit Port and L2 to the same numbered Downstream Receive Port as shown. (See the Digital Crosspoint Switch detail diagram, below.)

Single-Link, DVI 2 Display/KVM Destinations

STEP 1: Connect your VelocityKVM Receiver to the VX40 using multi-mode fiber-optic cables (up to 1000 meters). Connect L1 to any Downstream Transmit Port and L2 to the same numbered Downstream Receive Port. Connect L3 to any other Downstream Transmit port. (See the Digital Crosspoint Switch detail diagram, left.)

STEP 2: Ensure that the VelocityKVM Receiver's ON/OFF switch is in the OFF (0) position. Depending on your configuration, connect your desktop devices (monitors, keyboard, mouse, etc.) to the Receiver using standard cables as shown in the example below. Turn all the devices ON. Insert the AC power cord into the Receiver and plug it into a standard AC source. Turn the unit ON.

Thinklogical's™ VX40 KVM Matrix Switch features redundant Power Supplies and Controller Modules for uninterrupted performance, even during system reconfiguration, updates or debug. The VX40 remains fully functional with only one Power Supply installed or with one Controller activated.

NOTE: When using a single Controller, the module on the left (Primary) must be used.★